

INTEWA

INTEWA PRODUCTS



RAINMASTER Favorit-SC

Installation and user manual

WATER, WE' RE IN OUR ELEMENT

Table of contents

1. Introduction and scope of application	2
1.1 Modes of operation	3
2. Safety instructions	4
3. Scope of delivery	5
4. Technical Data	6
4.1 Device overview and dimensions.....	7
4.2. Dimensions of the intake line	8
4.3 Standards, directives, tests.....	9
5. Overview of components	10
5.1 Components of the pump-controller.....	10
5.1.1 Description of display and buttons.....	10
5.1.2 Cable connection plan	12
5.1.3 Self-regulation check.....	13
5.1.4 Advanced regulations / setting mode	14
5.2 Components of basic controller.....	17
5.3 Components of the multistage pump	19
5.4 Components of supplemental supply.....	20
5.5 Components of the electronic 3/2-way ball valve.....	20
6. Installation instructions	21
6.1 Wall mounting.....	21
6.2 Connection to the mains water line.....	22
6.3 Installations on the suction side.....	23
6.3.1 Installation of a protective conduit pipe.....	23
6.3.2 Layout of the intake line	24
6.3.3 Intake line connection.....	25
6.3.4 Installation of the floating intake	25
6.4 Installation of the pressure line set	26
6.5 Connecting the emergency overflow	27
6.6 Installation and adjustment of the float switch	28
7. Start up and use	29
7.1 Start-up in mains water mode	29
7.2 Start-up in rainwater mode.....	30
7.3 Modes of operation and display	31
7.3.1 Automatic mode (Switching position I)	32
7.3.2 Maintenance mode (Switch position II).....	32
8. Safety monitoring and error notifications	33
9. Trouble shooting in case of problems	34
10. Maintenance	35
11. Spare parts	35
12. Optional Accessories	36
13. Guarantee	36
14. Contact / unit serial number	36
Annex 1.0 Scope of duplex or triplex application	37
Annex 1.1 Intake variants	37
Annex 1.2 Technical data for duplex- and triplex-application	39
Annex 1.3 Group function via Bluetooth by duplex and triplex applications	40

1. Introduction and scope of application

Congratulations on purchasing your **RAINMASTER Favorit-SC** (*RM Favorit-SC*).

The RM Favorit-SC is specially designed for water harvesting (e.g. rain water, grey water or cooling water) in large single family dwellings, multiple family dwellings and in commercial and industrial applications.

The maximum installation height for consumers above the RM Favorit-SC 20 is 20 m and above the RM Favorit-SC 40 is 30 m.

The application range can be enlarged by a series up to three RM Favorit-SC. The plant control system is realised by wireless Bluetooth.

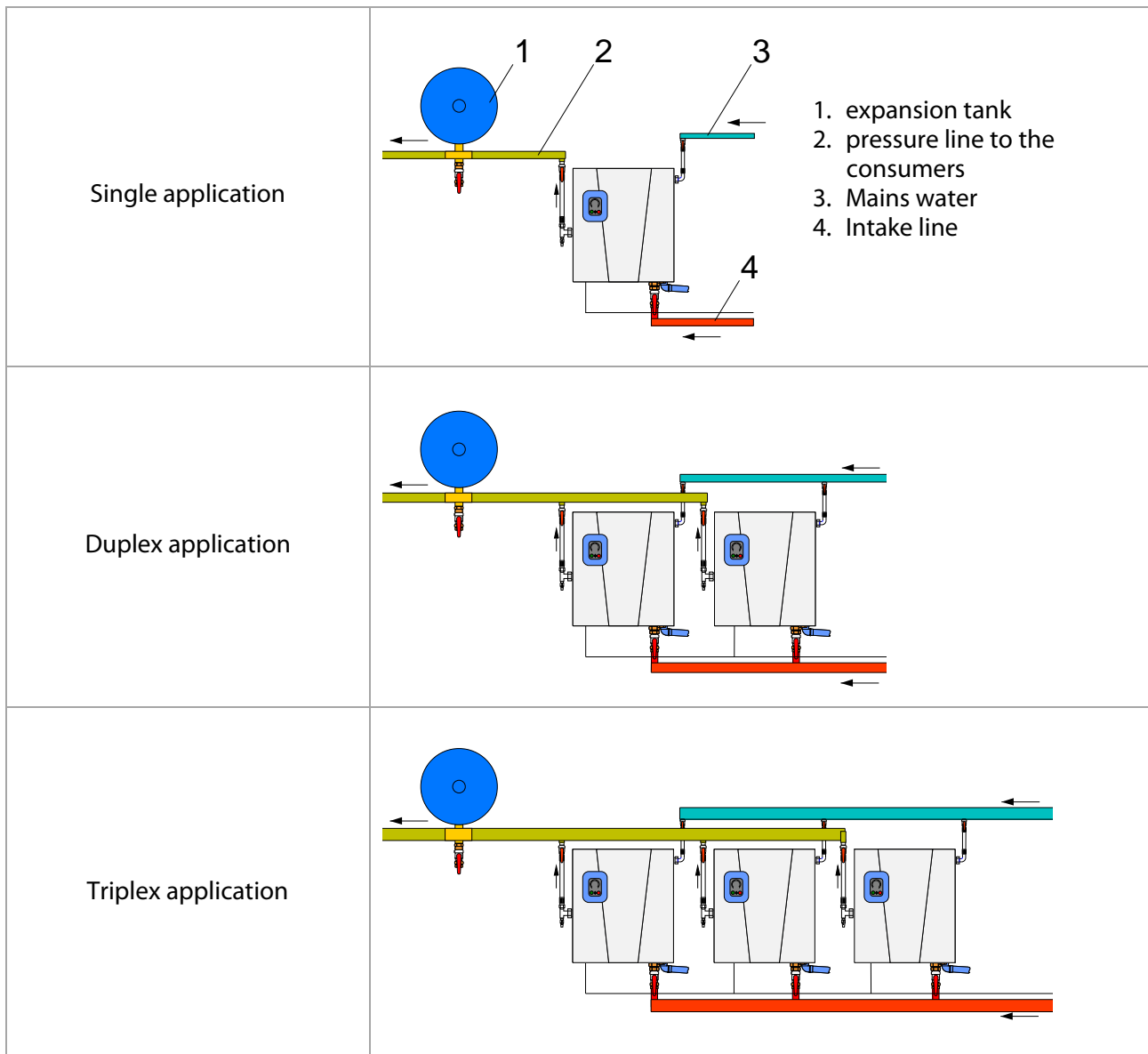

1.1 Modes of operation

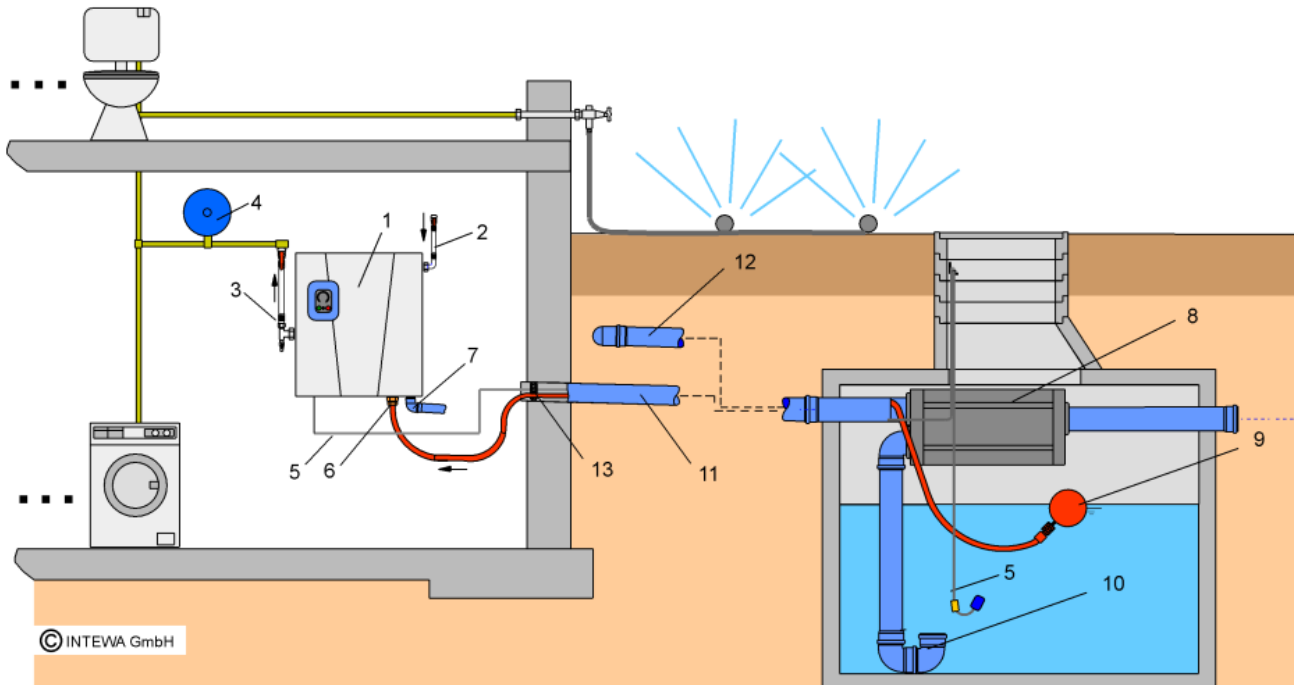

An example of a rainwater harvesting system with external storage and RM Favorit-SC

- | | |
|---|---|
| 1. RAINMASTER Favorit-SC | 8. PURAIN rainwater filter |
| 2. Mains water connection | 9. Floating intake filter model SAUGSAGF |
| 3. Pressure line set with air vent and stopcock | 10. Quiet inflow |
| 4. Pressure line to house with expansion tank | 11. Protective conduit pipe for suction line and sensor cable |
| 5. Float switch cable | 12. Rainwater line into the tank |
| 6. Suction line | 13. MD100 wall bush |
| 7. Emergency overflow | |

Automatic mode

In Automatic mode, the pump carries rainwater from the tank into the home and onto respective applications (e.g. toilets etc.). If the tank is empty, this is detected by the float switch in the tank, which instructs the electronic 3/2-way ball valve to change to the mains water mode. The rainwater intake line is then blocked and the required mains water is sourced from the built-in supplemental supply container inside the *RM Favorit-SC*. After it rains, and the tank is topped-up with rainwater again, the float switch detects this and the electronic 3/2-way ball valve switches back to the rainwater intake setting.

Maintenance mode

In maintenance mode, the electronic 3/2-way ball valve stays permanently switched to mains water mode, and the house is continuously supplied with mains water from the supplemental supply container inside the *RM Favorit-SC*.

Speed control

In both modes (automatic/maintenance), the speed of the centrifugal pump is controlled by a frequency converter corresponding to the set pressure level. The pressure is monitored via a built-in analog pressure sensor. The current is monitored via the power controller. This 100% ensures that the pump never runs dry. All operating parameters such as delay time, idle and load power consumption and response time for the running dry are specified by the controller.

Bluetooth connection

Two to three series of *RM Favorit-SC* can communicate with each other without any wires via the integrated Bluetooth and can be conveniently combined in a fully redundant multiple pumping system. The pairing, the cyclic switching of the pumps, the connection with peak load and the Master/Slave exchange is done automatically in case of the failure of device.

2. Safety instructions

This installation and operating manual is to be read carefully before installing the device. The instructions specified here are to be accurately followed, as failure to do so may lead to rejection of any warranty claim. Moreover, any modification of the supplemental supply device or the electronic inside the unit will immediately nullify the warranty.

The user is responsible for compliance with safety and installation regulations. Only the original provided packaging is to be used for transportation of the equipment.

The emergency overflow of *RM Favorit-SC* must always be connected.

Installation of the mains water line must only be carried out by an authorized installation company.



The *RM Favorit-SC* internal housing for live electrical components shall only be opened by a qualified electrician.

The electrical circuit used to power this device must be protected by a 16A circuit breaker. Likewise, an ELCB (earth-leakage circuit breaker), with a maximum operating current of 30 mA, is to be used.

The operator is responsible for the compliance with safety regulations and for following these installation guidelines.

3. Scope of delivery

RAINMASTER Favorit-SC unit



Wall mounting material and installation and user manual



Standard accessory A
(Mains water connection):



Standard accessory B
(Pressure line set):



Standard accessory C
(Float switch):



4. Technical Data

	RM Favorit-SC 20	RM Favorit-SC 40
Dimensions (H x W x D):	595 x 550 x 265 mm	595 x 550 x 265 mm
Weight:	33 kg	34 kg
Nominal power supply input / power frequency:	230 V AC / 50-60 Hz	230 V AC / 50-60 Hz
Supply voltage range:	207 ... 244 V	207 ... 244 V
Max. power rating:	max.0,8 kW	max. 1,25 kW
Power supply output pump controller:	3 x 230 V / 0-55Hz	3 x 230 V / 0-55Hz
Max. power intake pump:	max. 2,6 A	max. 3,5 A
Operating pressure:	2,0 - 4,5 bar (adjustable)	2,0 - 5,5 bar (adjustable)
Max. volume flow rate:	80 l/min	110 l/min
Noise level:	35 - 60 dBa	35 - 65 dBa
Intake height (self-priming):	0 - 4m (see intake diagram)	0 - 4m (see intake diagram)
Protection class:	IP 54	IP 54
Max. mains water pressure:	2,5 - 6 bar	2,5 - 6 bar
Highest consumer above RM Favorit:	20 m	30 m
Float switch:		
Cable length x Cross section:	15 m x Ø9 mm, (3 x 1,0mm ²)	15 m x Ø9 mm, (3 x 1,0mm ²)
Protection class:	IP68	IP68

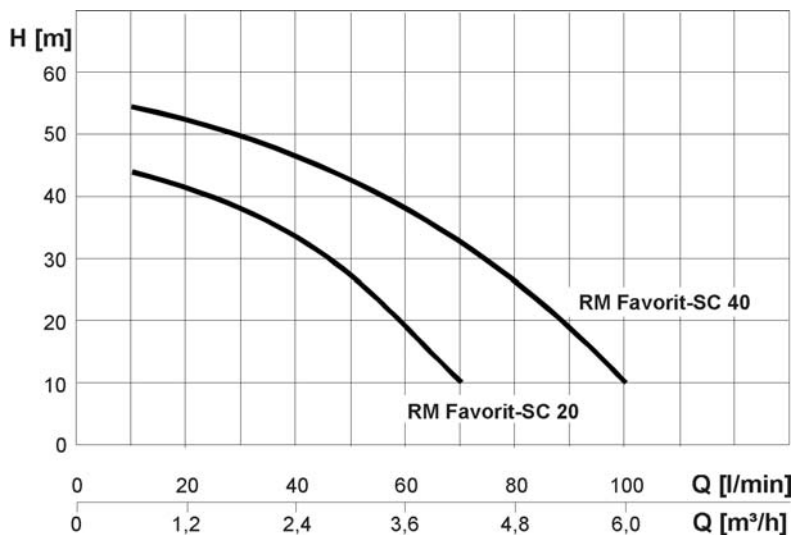

Performance curve of the pump

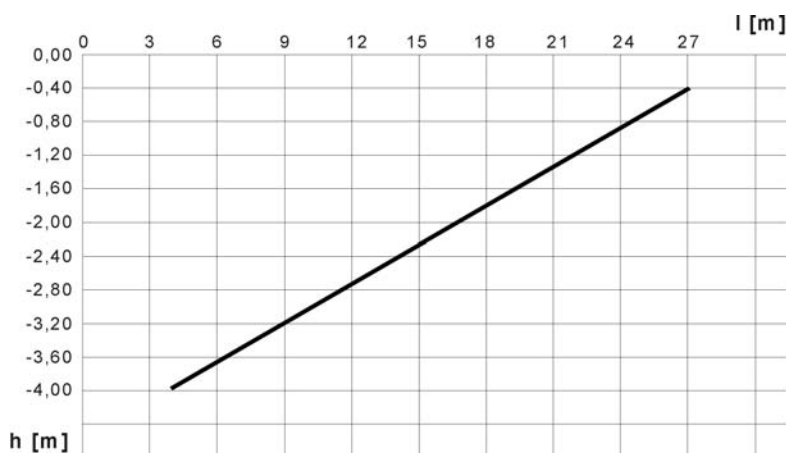

Performance curve of the intake for RM Favorit 20/40

4.1 Device overview and dimensions

View from right

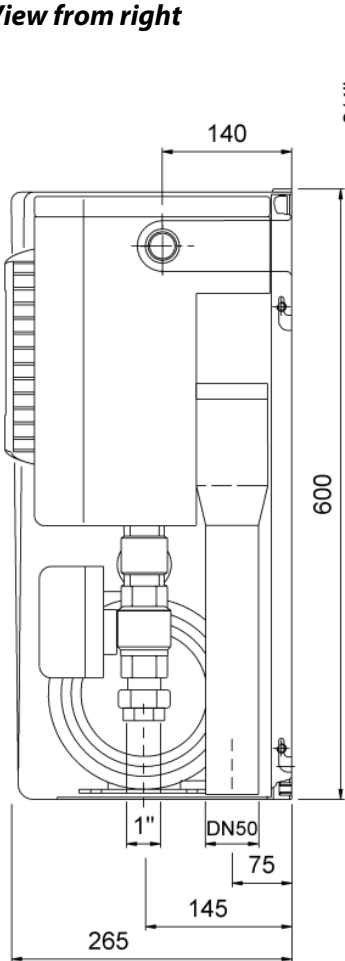

Front view

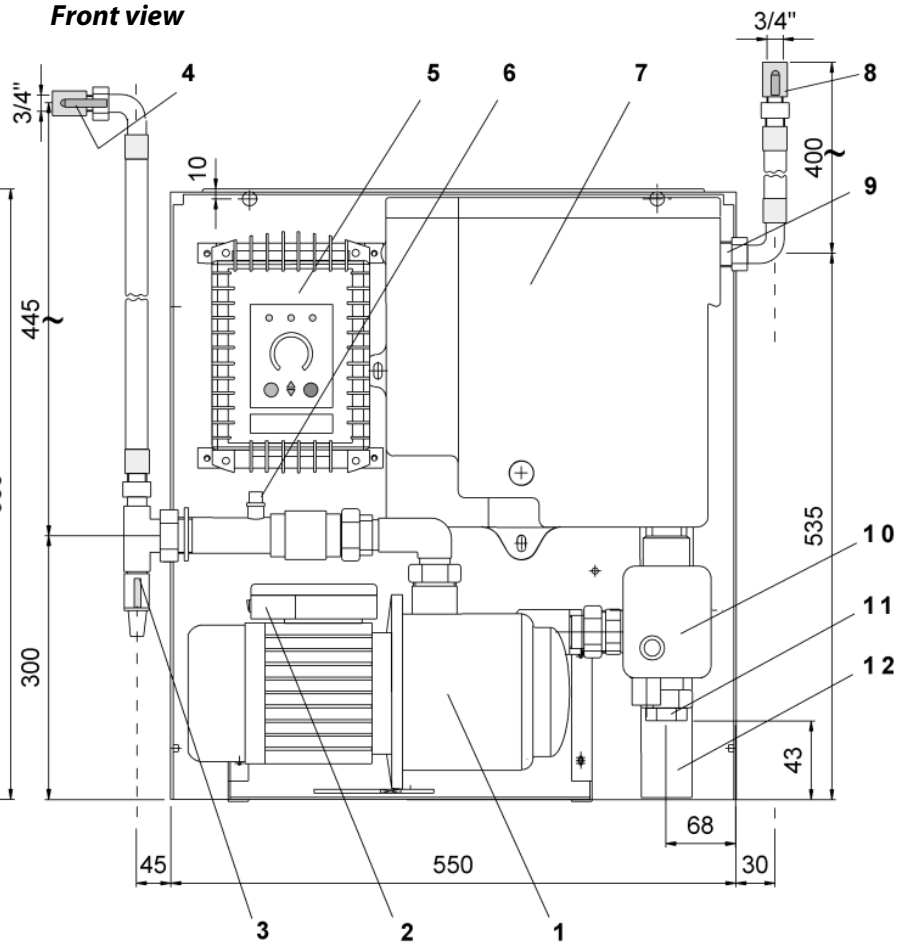

View from left

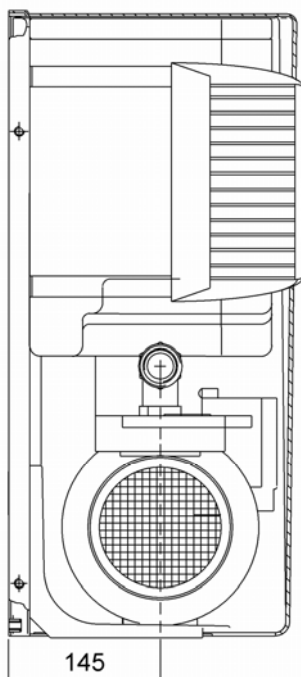

1. Multistage pump RM Favorit-SC 20 / 40
2. Pump terminal box with basic controller
3. Vent cock
4. Pressure shut-off valve (1" female)
5. Pump-controller (speed control)
6. Pressure sensor 4-20 mA, 1/4" male
7. Supplemental supply container
8. Stopcock for mains water (3/4" female)
9. Mains water floating valve
10. Electronic 3/2-way ball valve with display
11. Intake line (1" female)
12. Emergency overflow line DN 50 (Ø 55mm)

4.2. Dimensions of the intake line

In practice, the self-priming function of the pump depends due to decrease in pressure (pipe friction, suction level) only in a certain range. In this operating range, the pump can evacuate the air out of the suction line (for example, with initial start-up operation). The performance curve of the intake line indicates the dependence of intake length on the intake level. The determined value is above the represented intake line in the diagram. If the intake point is below the intake performance line, then a hybrid tank with charging pump is necessary (see Annex1.1).

Sample dimensions:

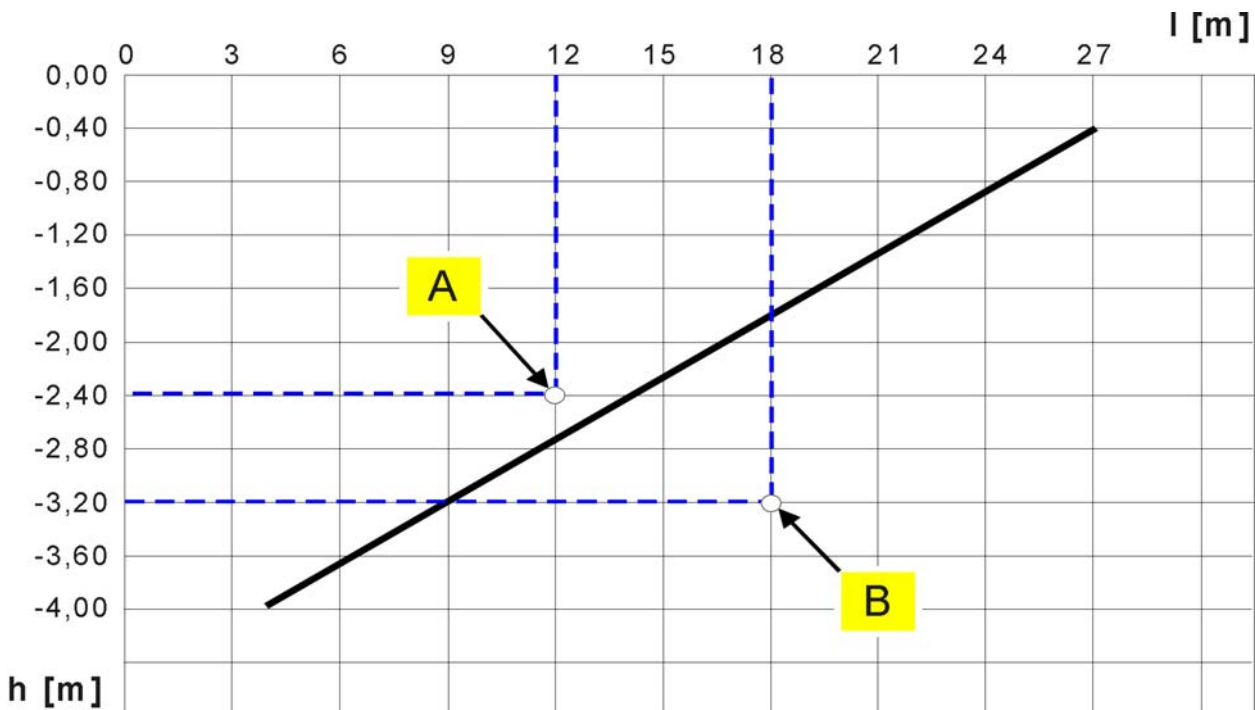

Example A:

Length of suction pipe: = 12 m

Intake level: = 2.40 m (Height difference between deepest intake level and pump)

→ o.k. because it's above the performance curve

Example B:

Length of suction pipe: = 18 m

Intake level: = 3.20 m (Height difference between deepest intake level and pump)

→ not o.k. because it's below the performance curve

→ hybrid tank with charging pump is required (see Annex 1.1)

4.3 Standards, directives, tests

The *RM Favorit-SC* meets the DIN 1989-4 "Components for Control and Supplemental Supply" standards for rainwater harvesting systems. The DVGW mark of approval confirms the presence of the mandatory "air gap" (as per DIN EN1717) for secure separation of processed water from the mains water line, which is integrated into the *RM Favorit SC*.

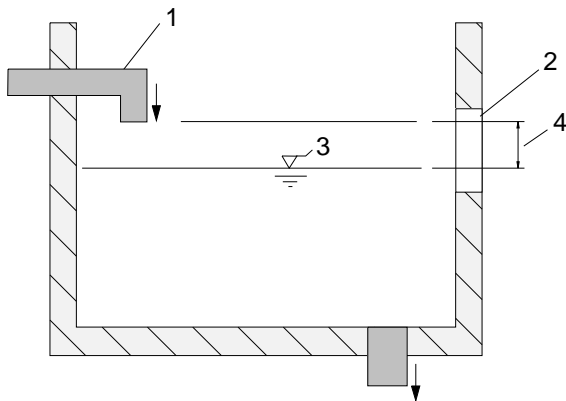

1. Mains water inlet (floating valve)
2. Emergency overflow
3. Max. water level (in case of malfunction)
4. Air gap between inlet and max. possible water level = secure separation of mains water and processed water

Mains water supplemental supply device, Type AB as per DIN EN 1717

The above mentioned device corresponds with the basic safety and health requirements of the EC directives for machines. Any modification of the device not coordinated by INTEWA will void the warranty.

This equipment specifically fulfils the requirements of the following EU directives:



EC directives for machines (89/392/EWG) in accordance with 91/368/EWG
EC Low voltage directives (73/23/EWG)
EG Directives for electromagnetic compatibility (89/336/EWG) in accordance with 93/31/EWG

The conformity of the equipment with the above mentioned directives is confirmed by the CE symbol.

Applied harmonized EU standards:

EN 60335-1: 1194/A1/A11/A12/A13/A14, EN 60335-2-41: 1996

Applied standards and technical specifications:

DIN 1988-2, DIN 1989-4, DIN EN1717, DIN EN 13077, BGA KTW

Tests/Monitoring:

Mains water supplemental supply device:
DIN-DVGW mark certified



5. Overview of components

The *RM Favorit-SC* has a modular design. Each component can be separately changed.





5.1 Components of the pump-controller

The pump controller (see image chapter 4.1) monitors the pressure in pressure line system and maintains it at a constant level by speed controller. The controller reduces the power consumption especially with small volume flow rate and increases the service life of the pump.







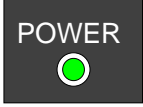
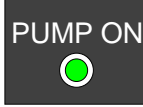

1. Motor pump OUT, 3-phase
2. Pressure sensor (4-20 mA output), 1/4" male
3. Power supply 230 V AC/50Hz

5.1.1 Description of display and buttons

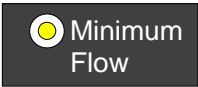
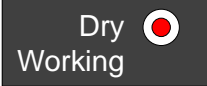
Button	Description
	<ul style="list-style-type: none"> - increases the working pressure (reference pressure) by 0.5 bar per keystroke (possible at any time during operation) - allows to go up on the advanced regulation functions also
	<ul style="list-style-type: none"> - reduces the working pressure (reference pressure) by 0.5 bar per keystroke (possible at any time during operation) - allows to go down on the advanced regulation functions also
	<p>START</p> <ul style="list-style-type: none"> - starts Self-Regulation-Test on the first installation or after a RESET
	<p>STOP</p> <ul style="list-style-type: none"> - instant Stop of the motor pump



Circular Led indication	Description
	<p>Power Green fixed: Inverter voltage supply is ON</p>
	<p>Pump ON Green fixed: Pump ON Green flashing: Enable OFF condition</p>
	<p>ALARM Red fixed: Pump stop for a problem that need manual restart (STOP then START) Red flashing: Pump stop for a problem with auto re-start</p>
	<p>Minimum Flow Yellow fixed: Pump stop for minimum output flow (s. F1) Yellow flashing: Pump is stopping for minimum flow(s. F14)</p>
	<p>Dry Working Red flashing: Pump stop for dry working condition of the pump, during one of four re-start of this problem, separated from 15 minutes Red fixed: final stop after 5th consecutive stop for this problem</p>
	<p>Circular LED indication</p> <ul style="list-style-type: none"> - manometer shape to indicate the instant pressure(0,5bar steps) - indication of the adjust pressure range about until 3 seconds after pressing <div style="display: flex; align-items: center; justify-content: center;">  or  </div> <ul style="list-style-type: none"> - Settings indicator in setting mode - In ALARM condition to each led corresponds a different type of alarm

5.1.2 Cable connection plan

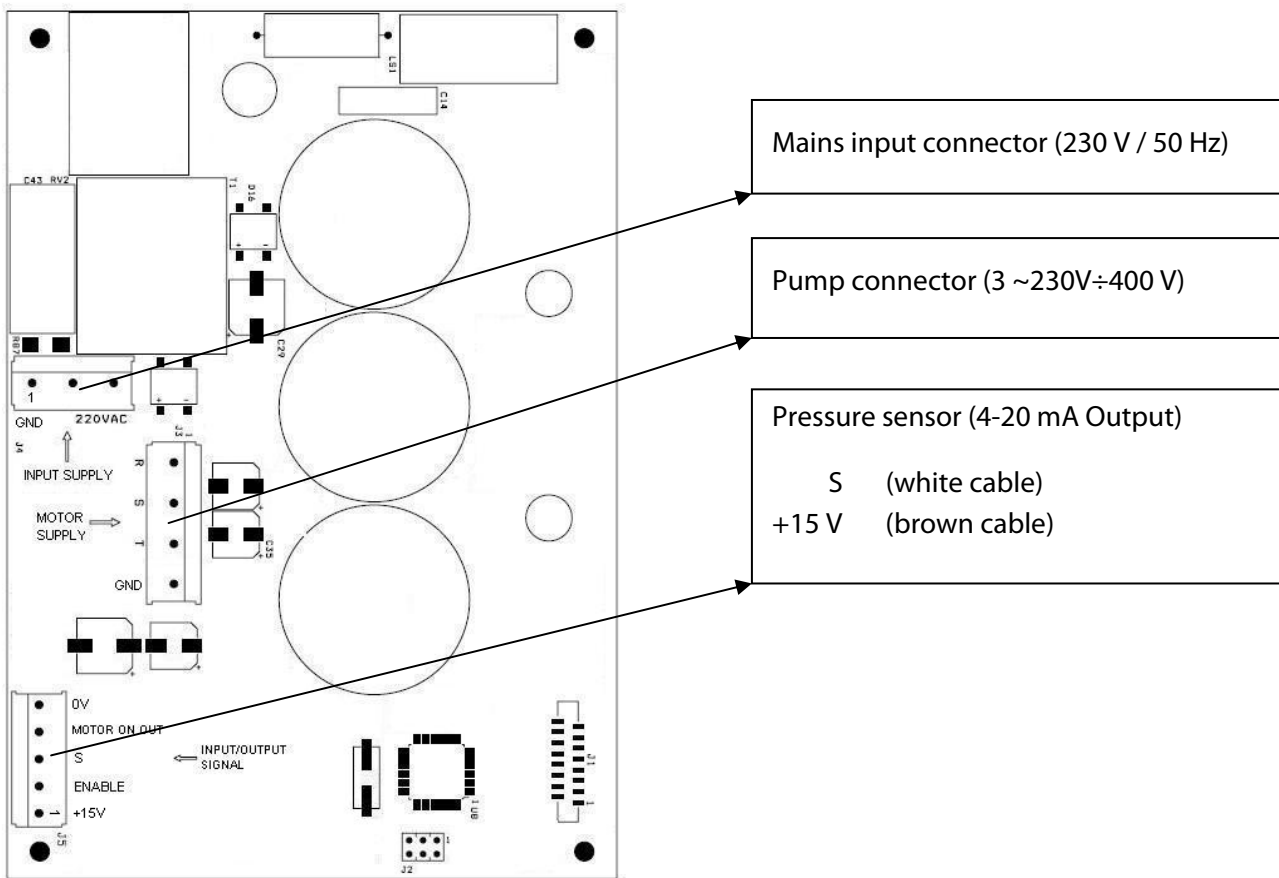

In the event of a damaged cable or faulty pressure sensor, it is necessary to open the housing of the pump control. For this purpose, the mains plug must be disconnected and you have to wait for at least 2 minutes until all LEDs turn off (internal capacitors are discharged). You may open the case only after this. For this purpose, you have to demount the complete pump control from the angle holders. Then the rear screws of the heatsink can be opened.

5.1.3 Self-regulation check

The pump controlled is preinstalled in the respective pump with *RM Favorit-SC!*



The below mentioned self-regulation must be performed **only** when a Program RESET was conducted or if a new pump or a new pump control system was used.



In this automatic initialization, the characteristic current values are passed at different operating parameters, which form the basis of the speed controller.

- 1.) Make sure the pump is charged with water (see chapter 7.1) when pump get the first time in function
- 2.) Open the air vent and let water flow until there is no more air in the system. Then, close the pressure shut-off valve (pressure builds).
- 3.) In case the pressure of the system is more than 3 bar open the stopcock again to reduce the pressure under 3 bar (very important condition).

4.) Press  to start the self-regulation check. After about two minutes (combined pressure measure range of the pump will continue), the initialization is finished. The LED indicator lights up one time, from 0 all the way to 10 bar and the pump stops (LED „Minimum Flow“ lights up).

5.) The self-regulation check is now closed and the start-up operation can follow (see chapter 7.2). Changing the predefined operating pressure of 3 bar is only possible, if necessary, in 0,5 bar steps by

pressing the  or  button. (If the LED indicator doesn't blink anymore, the pressure value has been saved

Command	Button combination
RESET (to restore constructor data)	 &  press them simultaneously for 5 seconds (Led indication total blinking for one time). Then full the power supply plug and wait until there is no LED Indication!
Starting SELF-REGULATION	Pull in the power supply plug. Press  to start the self-initialization.

Checking the pump stop for delivery closed

At the end of the self-regulation check, done with the delivery of the pump completely closed (all of the output valves closed) the pump shall be automatically stopping and the Inverter could show the message "MINIMUM FLOW" by the corresponding Yellow LED. The stop is preceded by a phase of flashing LED "MINIMUM FLOW". Verify that the pump stopped and after that the pump re-start working when opening any valve on pump delivery.

Checking the arrest of the pump dry running







After installing, if is possible, close the water input of the pump and check that, after approximately 40 seconds, the pump stop and show the message "DRY WORKING" with corresponding Red Led.





5.1.4 Advanced regulations / setting mode













In default setting, the parameters are adjusted on the pump of RM-F SC. However, it has an option of making precise settings in setting mode.





Attention!

This shall only be performed by an experienced skilled technician.

Command	Button combination
Enter on Advanced Regulations	 &  press them simultaneously for 3 seconds until the LED indication completely is blinking for a short moment and the regulation of F1 is shown on the Led indication.
Retrieve next setting value	Keep the  button pressed. By pressing  , the next setting value is selected. By releasing the buttons, the current setting value is shown.
Retrieve next setting value	By pressing  or  a step is increased or decreased. (The LED indication display up to 20 Steps.)
Confirm the setting values	By pressing  , you confirm the settings and exit the setting mode.

N.	Visualization	Advanced Function	Description	Range	default
F1		Minimum flow stop	Adjustment of the minimum flow before pump stop, from the self-regulation value setted.	10...+10 Step: 1	0
F2		Maximum Motor current	Maximum RMS current setting: limit value for over-current RM F-SC 20: 3,0 A RM F-SC 20: 3,5 A	1...7 A Step: 0.5 A	7 A
F3		Minimum Motor Velocity	Minimum motor velocity adjustment. (Reference: nominal velocity of 2850 min-1)	30..70% Step: 2%	50%
F4		Maximum Motor Velocity	Maximum value of the motor velocity on respect to the nominal velocity of 2850 min-1.	90..110% Step: 1%	105%

F5		Rotation direction	0/1	0/1	0
F6		Starting maximum Current	Speed ramp during acceleration	1000-10000 RPM/s Step: 500	3000 RPM/s
F7		Maximum pressure	Maximum security pressure of the system.	2 ...10 bar Step: 0.5 Bar	10 bar
F8		Pressure Hysteresis	Adjustment of the control pressure hysteresis.	0.15 ..1 Bar Step: 0.05 Bar	0.3 Bar
F9		Pressure ramp	Adjustment of the control pressure ramp on increasing/decreasing.	0.1 .. 2 Bar/s Step: 0.1 Bar/s	1 Bar/s
F10		Minimum output value of the pressure transducer	Adjustment of the minimum output value of the pressure transducer.	1..5 mA Step: 0.2 mA	4 mA
F11		Maximum output value of the pressure transducer	Adjustment of the maximum output value of the pressure transducer.	10.. 20 mA Step: 0.5 mA	20 mA
F12		Pressure transducer measure range	Adjustment of the pressure transducer range.	10..20 Bar Step: 0.5 Bar	16 Bar
F13		Proportional P.I.D. Factor	Proportional factor on the P.I.D.pressure control.	0..6000 Step: 300	3000
F14		Integral P.I.D. Factor	Integral factor on the P.I.D. pressure control.	0..4000 Step: 200	1000
F15		Minimum flow stop delay	Delay time on the minimum flow condition before stopping pump.	2..20 sec Step: 1 sec	12 sec
F16		Dry working stop delay	Delay time on the dry working condition before stopping pump.	10..100 sec Step: 5 sec	40 sec

F17		Master-Slave group communication	Operating mode with 1, 2 or 3 pumps with Bluetooth connection, factory setting for 2 pump system that is also used for single pump mode	1: single pump 2: two pumps MASTER/SLAVE 3: three pumps MASTER/SLAVE	
F18		Check setting	Refers to the graph of the power consumption	0: Theoretical curve 1: Start new check 2: Checked curve	1
F19		Measurements	Measures of different parameters	0: Pressure (0..10) 1: Frequency (15..55) 2: Current (0..10) 3: Voltage (200-.240) 4: T [°C] (70..90) 5: Last alarm 6: Motor $\Delta T[°C](0..100)$	0
F20		Radio Frequency transmission/reception	Frequency of Transmission/ Reception of the radio communication between 2 or 3 inverters	780 .. 820 MHz Step: 1 MHz	800 MHz

5.2 Components of basic controller

The unit's basic controller is located in the terminal box of the pump. Here are all the electronic components of the *RM Favorit-SC* are connected. On the side of the terminal box is the mode selection switch I / II (position [1]) for Automatic and Maintenance mode. (see chapter 7.3 for functional description)

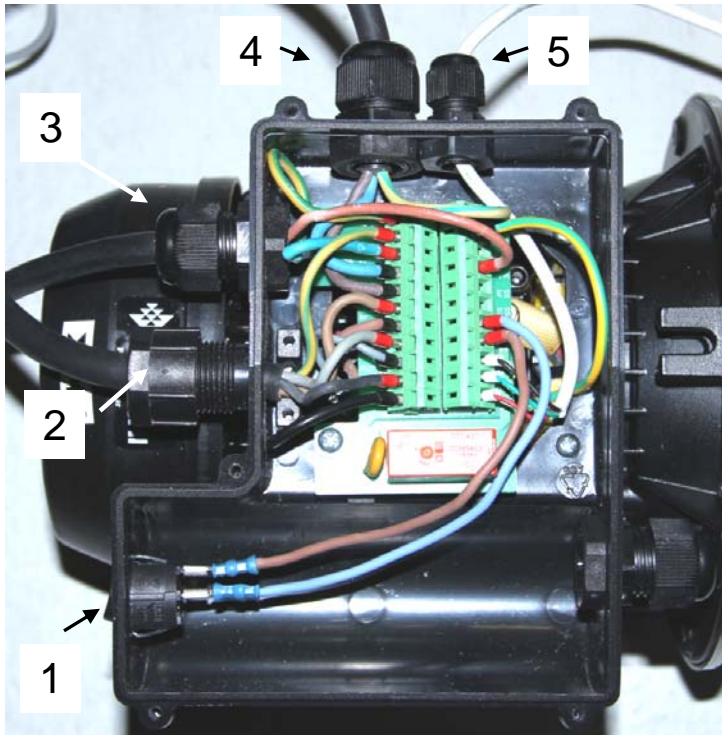

1. Selection switch
2. Pump control OUT, 3-phase
3. Mains connection ~230V AC/50 Hz
4. Mains pump control
5. Connection motorized ball valve

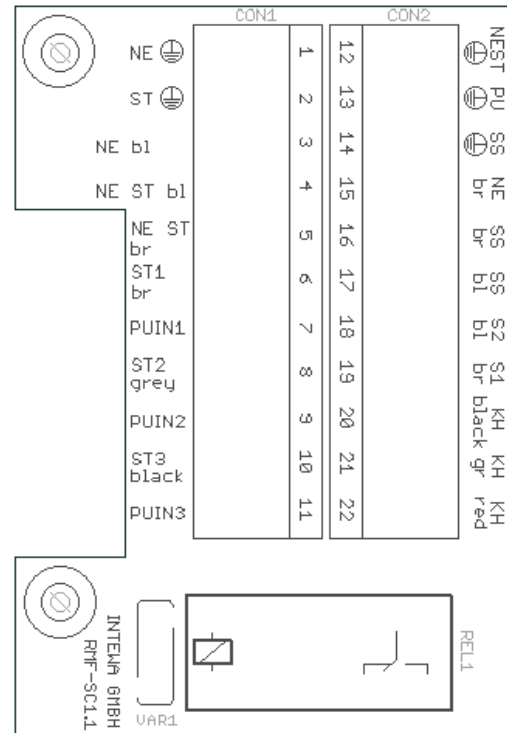

item	Board inscription	Description of connection
1	NE PE	Protective conductor mains connection
2	ST PE	Protective conductor pump controller
3	NE bl	N-Mains connection 230V~, blue
4	NE ST bl	N-Mains,Pump controller blue
5	NE ST br	L1-Mains,Pump controller brown
6	ST1 br	OUT-Pump controller brown
7	PUIN1	IN-Pump brown
8	ST2 grey	OUT-Pump controller grey
9	PUIN2	IN-Pump grey
10	ST3 black	OUT-Pump controller black
11	PUIN3	IN-Pump black

item	Board inscription	Description of connection
12	PU PE	Protective conductor pump
13	SS PE	Protective conductor floating switch
14	ST PE	Protective cond. pump controller
15	NE br	L1-Mains connection 230 V~, brown
16	SS br	Floating switch brown
17	SS bl	Floating switch blue
18	S2 bl	Selection Switch blue
19	S1 br	Selection Switch brown
20	KH black	Ball valve black
21	KH gr	Ball valve green
22	KH red	L1-Ball valve red

Table: Overview of the cable connections





Floating switch preparation	/Selection switch	Electrical contact
		
		

Table: Electrical switching conditions of the floating switch and selection switch

The mode selection switch is wired with a flat pin plug.

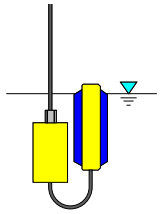

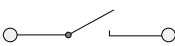
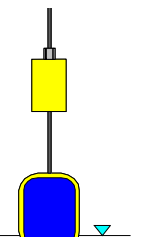
5.3 Components of the multistage pump

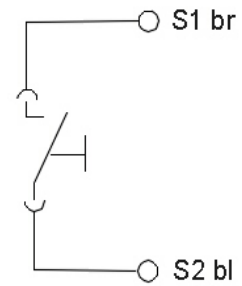
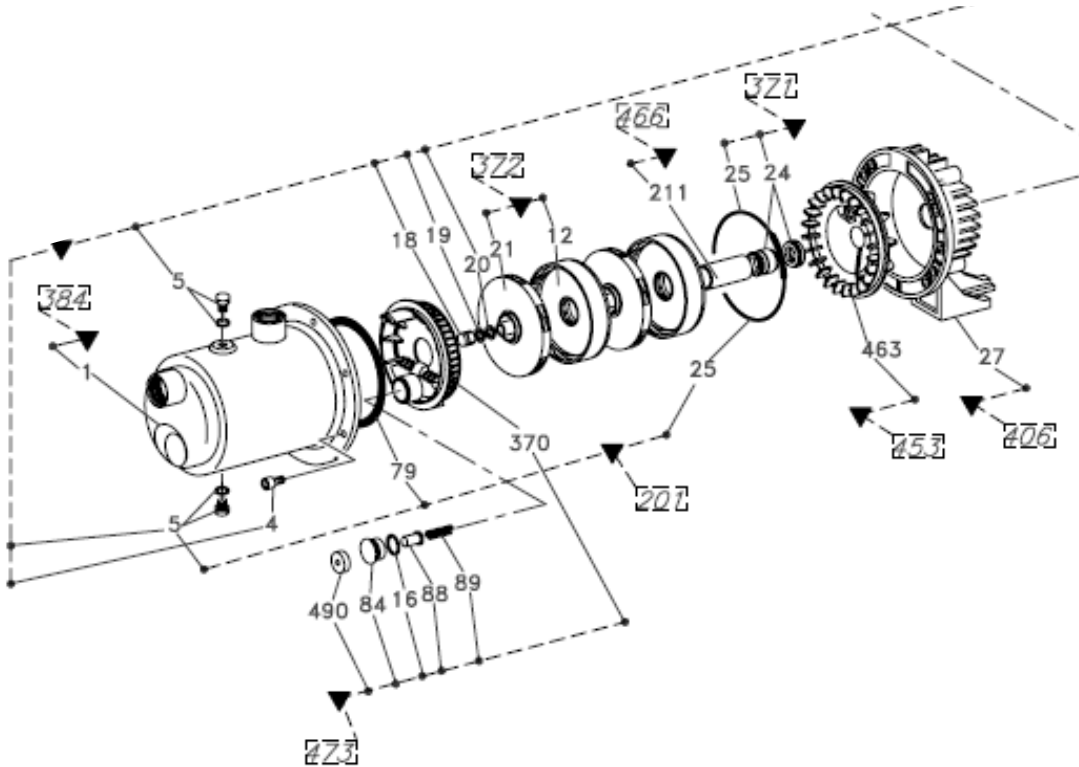

Expanded view of *RM Favorit –SC 20/40* centrifugal pump

KIT REF.	Nr. KIT DESCRIPTION	REF.Nr.	COMPONENT DESCRIPTION	RM F 20	RM F-SC 20	RM F 40	RM F-SC 40
371	MECHANICAL SEAL KIT	25	O-RING (PUMP BODY ~)	ZBR25620			1 pcs.
		24	SEAL (COMPLETE MECHANICAL ~)				1 pcs.
372	HYDRAULIC KIT	21	IMPELLER	ZBR24170		ZBR24180	1 pcs.
		12	DIFFUSER (WELDED ~)				1 pcs.
380	CAPACITOR KIT	47	CAPACITOR	ZBR 1	--	ZBR 1	--
473	SELF-PRIMING SUCTION FLANGE KIT	16	16 O-RING (NOZZLE ~) 1 pc	ZBR28140			1 pcs.
		84	84 PLUG (FRONT ~) 1 pc				1 pcs.
		88	88 SHUTTER 1 pc				1 pcs.
		490	490 RUBBER SPACER 1 pc				1 pcs.
		89	89 SPRING (SHUTTER ~) 1 pc				1 pcs.
		370	370 SELF-PRIMING SUCTION FLANGE				1 pcs.

List of spare parts for *RM Favorit* and *RM Favorit-SC 20/40*

5.4 Components of supplemental supply

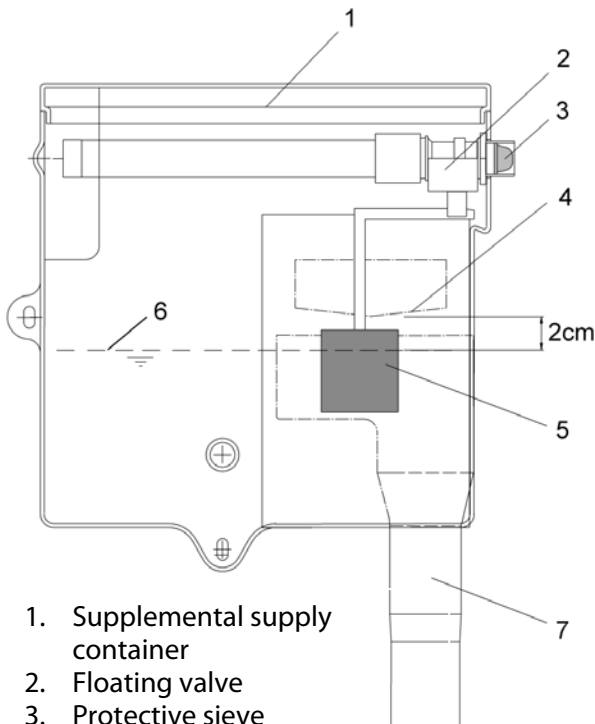

1. Supplemental supply container
2. Floating valve
3. Protective sieve
4. Emergency overflow rim
5. Lifting body
6. Maximum water level
7. Emergency overflow

The floating valve keeps the water level constant in the supplemental supply container. The maximum water level should be approx. 2 cm below the overflow rim when the floating valve is closed (backside of the container). The water level can be adjusted by twisting the black lifting body (5). The floating valve incorporates a protective sieve.

5.5 Components of the electronic 3/2-way ball valve

The motorised ball valve selects between rainwater intake and mains water intake. The built-in display shows which mode is currently selected.



Mains water mode:
(Pumps mains water from the supplemental supply container)

Rainwater mode:
(Pumps rain water from the rainwater tank)

6. Installation instructions

6.1 Wall mounting

The *RM Favorit-SC* is mounted on a wall with the supplied wall bracket. The lid and lateral distances indicated should be adhered to when mounting, to provide clear maintenance access.

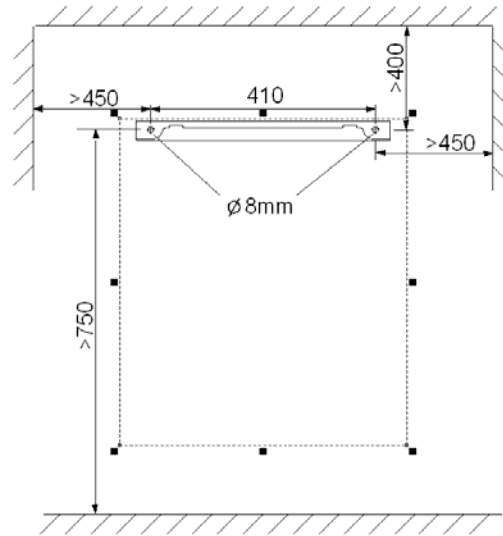

The *RM Favorit-SC* is wall mounted in such a way, that the groove in the top back panel of the unit hangs off the affixed wall bracket.



The provided rubber clamping device is to be fit on the back side of the unit in the lower corners. Thanks to the rubber pads, the device can be installed close to the wall. The unevenness of the wall can be balanced by various screwing depths.

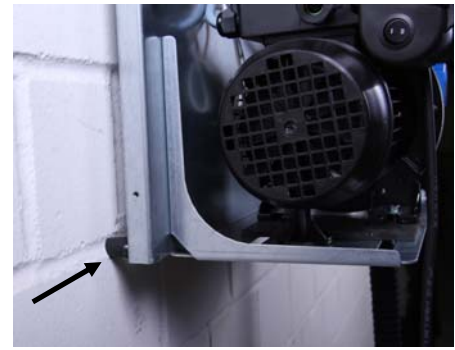

6.2 Connection to the mains water line

The connection to the mains water supply is done with the provided flexible hose and stopcock.

Screw the gland screw into the container connection and carefully tighten with a fixed spanner.

Note:

The flexible hose must not be overtightened as this may interfere with the internal float valve, on the opposite side of the connection. All provided flexible hoses have gland screws with flat washers. The rubber washers must be present. Additional sealing material must not be used on gland nuts!



Screw the gland screw on the other end of the flexible pipe into the stopcock mounted on the mains water line.



6.3 Installations on the suction side

The installation of the intake requires special attention, since only correct mounting and sealing ensures trouble-free operation of the system. For fault-free functioning, ensure the guidelines concerning intake height and intake length are followed carefully (see Chapter 4.2.).

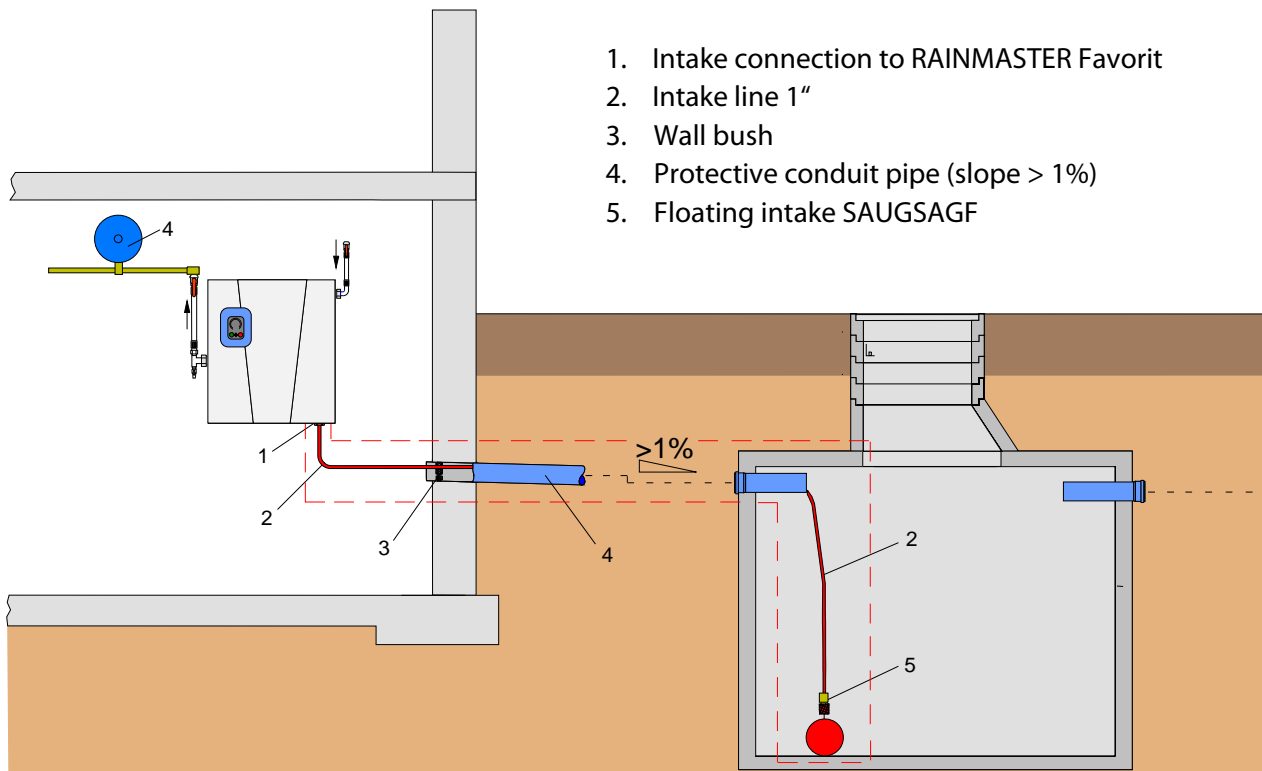

6.3.1 Installation of a protective conduit pipe

The intake line must be installed in a (DN100) protective conduit pipe in order to ensure all intake lines and pipes are protected from damage and can be accessed freely at any time. In order to avoid water accumulating in the conduit, it must be installed with > 1 % slope back towards the tank.

In general, all lines carried in the protective pipe should pass through a wall bush (for example INTEWA MD100 Article number: 61 00 50), at the house. This prevents water from outside entering the basement/garage/utility room. The wall bush must be mounted as per instructions so that the intake line is never squeezed or kinked (narrowing of the cross section).

6.3.2 Layout of the intake line

As intake line, a flexible negative pressure resistant hose that doesn't contract under vacuum should be used. This allows you to create a floating intake in the tank. The INTEWA intake hose SDS meets these requirements.

In order to avoid potential leaks at connection points, it is strongly recommended that the intake hose (from the intake filter in the tank all the way to the RM Favorit unit) should be one piece – containing no joins.

Warning instructions:

The internal diameter of the intake hose must be at least $D=26$ mm in order to obtain full volume flow.



No water filter may be used in the intake line, since the gaskets are not designed for underpressure. The underpressure for intakes cannot be built up later and the air enters the intake line.



PVC corrugated hoses are not suitable as rainwater suction lines. Experience has shown that after some time these become brittle and permeable to gas/air.



No flexible hoses can be used in the intake region since these soft, internal rubber coated hoses are constricted with underpressure.



The intake hose line must never bend, kink or be constricted in any way.



6.3.3 Intake line connection

The intake line is routed through the wall into the house, and connected to the RM Favorit.

The gland screw is to be tightened to the RM Favorit-SC connector. As the intake hose should not exert any force on the coupling to the unit, the pipe should be securely fastened to the wall with separate pipe clamps.



6.3.4 Installation of the floating intake

For best water quality, we recommend the intake line in the tank is installed as a floating intake.

The accessory product SAUGSAGF 1" (Article No. 21 01 30) is designed for this requirement. The rainwater is drawn from just below the water surface where the water is the cleanest. The integrated non-return valve ensures that water is always present in the suction line. The intake sieve provides additional protection against debris clogging the pump.

If the intake accessory is installed on site, make sure that the intake has a non-return valve, as well as an intake filter. The intake is mounted in such a way, that with the tank being empty, the intake sits at a minimum distance of 20 cm from the bottom of the tank. In this way, the intake of base sediment is safely prevented.

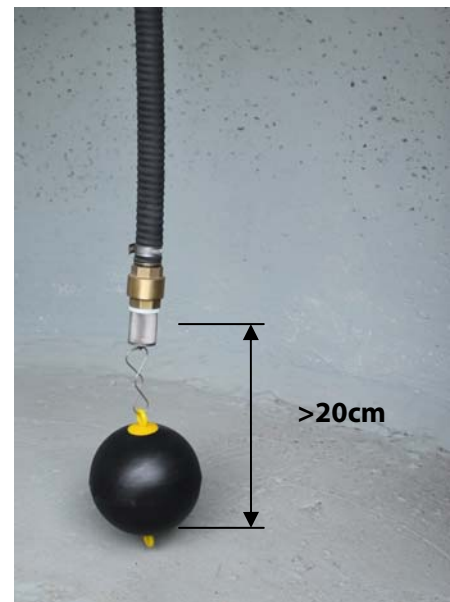

6.4 Installation of the pressure line set

The pressure line set (see scope of delivery) establishes the connection between the pump and pressure line system.

Attention:

For a smooth and efficient pressure regulation a 24 litres expansion vessel in the pressure line is absolute necessary. The air inlet pressure has to be 2 bar.

The pressure line set is connected to the pump controller.



The flexible hose and the shut-off valve then connect to the pressure line set and the pressure line.



Attention:

For an optimal and efficient pressure control, a membrane expansion tank of 5 l is absolutely necessary. The air pre-pressure has to be 2 bar.

6.5 Connecting the emergency overflow

The *RM Favorit-SC* has an emergency overflow line (DN 50) which must be connected to the waste drainage system of the building. The drainage line must be of a size to accommodate a maximum volume flow rate of 90 l/min.

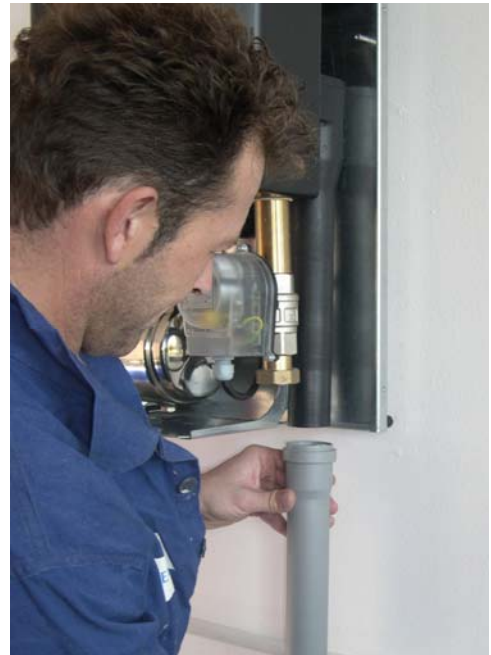

Note:

The position of the backwater level must be taken into consideration while connecting to a drainage system, in order to prevent backflow of drainage water from the open sewer line (design according to the DIN EN 1717) entering the *RM Favorit*.

The position of the backwater level determines the type of line:

- a) Backwater level **above** the emergency overflow drainage height of the supplemental supply container:
Connection of the emergency overflow must be done by a lifting system.

- b) Backwater level **below** the emergency overflow drainage height of the supplemental supply container:
Connection of the emergency overflow to a ventilated channel line (DN 50) is done via a siphon.

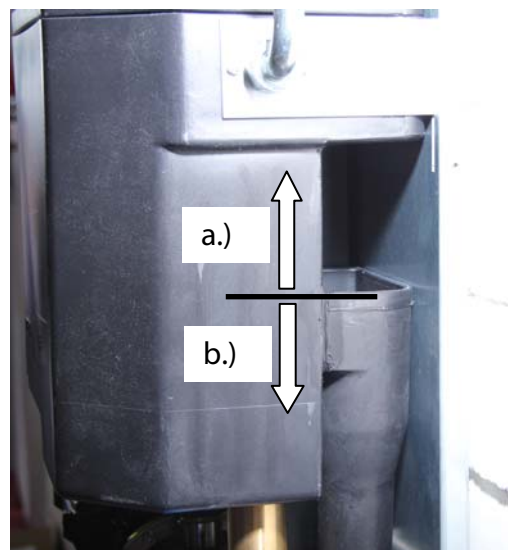

6.6 Installation and adjustment of the float switch

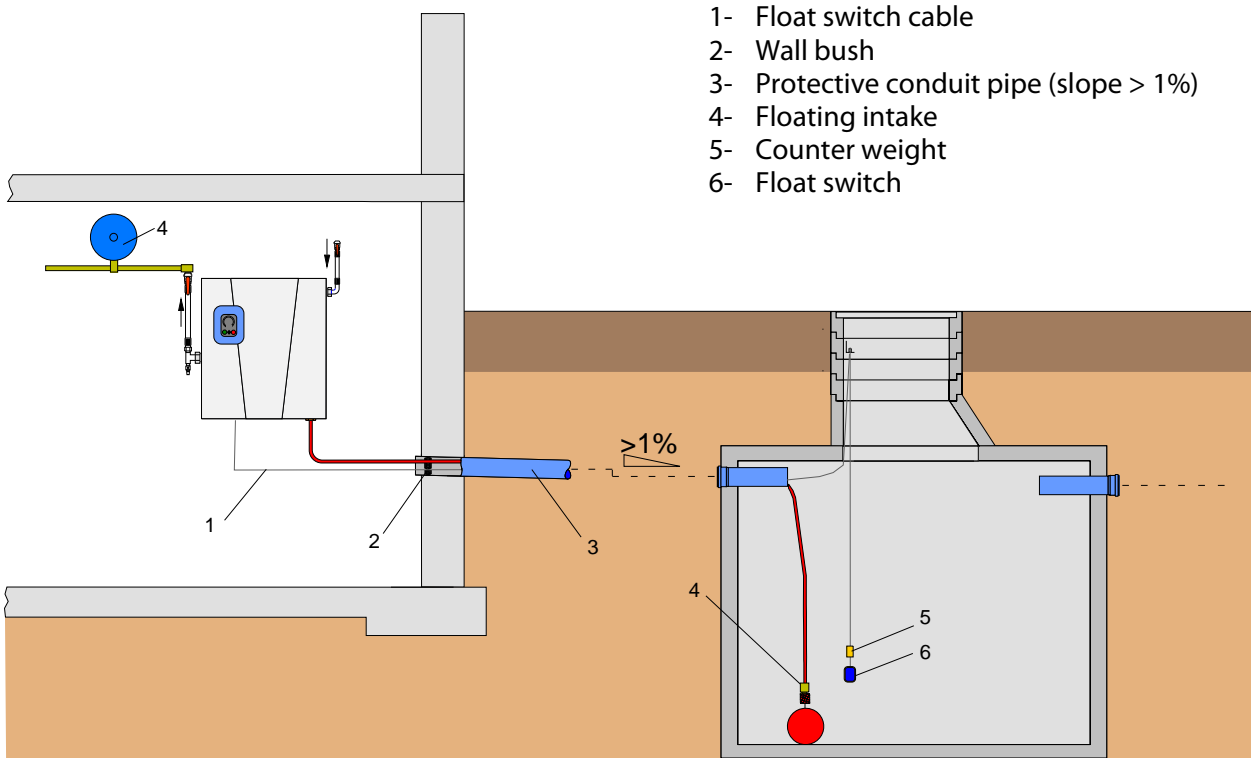

The float switch cable is housed in the same protective conduit as the intake line, for easy access and protection from damage. Therefore it is necessary to disconnect the cable from the pump terminal. Don't forget to fit the cable gland for the fixing point.

The fixing point for the float switch cable is installed in an accessible area of the tank opening so that it is possible to access (such as for inspection and maintenance purposes) even with a full tank level. The necessary height can be adjusted by means of the built-in cable gland.



The float switch counter weight (A) is mounted 15 cm above the float switch. The safety distance between the intake filter and the bottom of the float switch must be at least 10 cm (B), allowing the float switch enough cable length for free movement.

The float switch is electrically connected to the base controller (see Section 5.1).

Note:

The distance to all inner mounted parts in the cistern must be selected in such a way that the float switch can freely float.

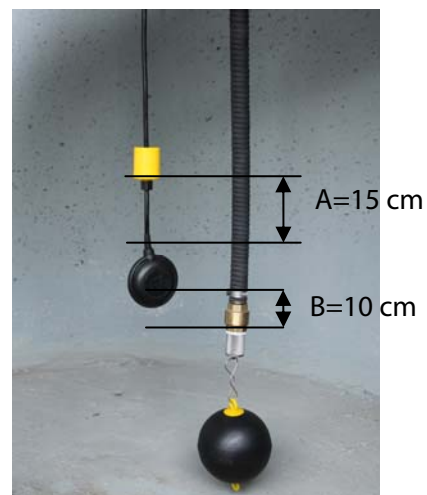

7. Start up and use

7.1 Start-up in mains water mode

1. Check that all lines are connected. Select maintenance mode = **Switch position II.**
2. Open the mains water line stopcock so that the supplemental supply container is filled with water.

Note:

In maintenance mode the pump primed with water automatically over the mains water tank. In this case the pump doesn't need to be filled up with water by hand.

Attention:

The pump must not be dry!

3. Close the pressure shut-off valve.

4. Open the air vent (hold a bucket of water under the air vent) and start the pump by plugging in the mains power. (Der 3/2-Wege- Kugelhahn fährt in Trinkwasserstellung, falls er noch auf Regenwasserstellung stand).

Let the water run from the air vent into the water bucket until there is no more sign of bubbles (a clear stream) meaning that all air has been removed from the suction line.

5. Close the air vent.



6. Open the pressure shut-off valve and release the air from the (house) line (e.g. by pressing the toilet flush several times or open the garden tap.).

7. Close all the consumers.

The pump will now automatically switch off when the maximum system pressure is reached.



7.2 Start-up in rainwater mode

Note:

If the mains water start-up operation is not successful on the first attempt (for example, if mains water is not available), then the pump must be primed with approx. one litre of water before initial start-up. This is done via the filling screw at the top of the pump. Only now the rainwater mode can be started!

Alternatively, the pump can be topped up by the potable water tank as well. For this purpose, the tank is filled with about 2 l of water and the pump is started in mains water mode.



1. Select Automatic mode = **Switch position I**

Note:

The rainwater mode can be started only if there is sufficient water in the rainwater tank. This can be seen when the 3/2-way ball valve in switch position I changes to the rainwater setting (see chapter 5.4).

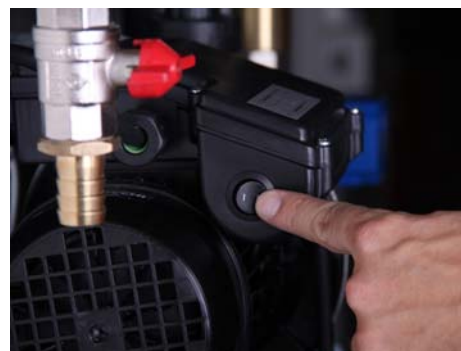

2. Close the pressure shut-off valve.



3. Open the air vent (hold a bucket of water under the air vent) and start the pump by plugging in the mains power. The motorised ball valve will move into the "rainwater" intake position.
4. Let the water run from the air vent into the water bucket until there is no more sign of bubbles (a clear stream), meaning that all the air has been removed from the suction line.
5. Close the air vent.



6. Open the pressure shut-off valve and release the air from the (house) line (e.g. by pressing the toilet flush several times or open the garden tap.).
7. Close all the consumers.
The pump will now automatically switch off when the maximum system pressure is reached.
The unit is now ready to use.



7.3 Modes of operation and display

The green LED on the pump controller indicates that the pump is ready to use. In case of a problem, the red LED will light up (see chapter 5.1)

The system pressure can be read on the pressure LED indication of the pump controller.

The Automatic Mode or Maintenance Mode can be set via the mode selecting switch.

7.3.1 Automatic mode (Switching position I)

Automatic mode is the normal operating mode, and is selected by Switch position I.

In this mode, the unit automatically switches from rainwater to mains water if the float switch detects that the rainwater tank is empty.

Two operating modes can be used according to the two positions of the float switch, both of which are indicated by the display of the motorized valve (see chapter 5.4).



- Rainwater mode:
Rainwater tank is full
(Float switch remains floating upright in the tank)

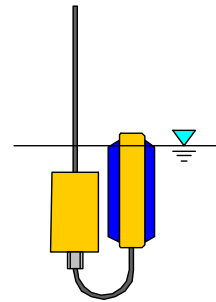

- Mains water mode:
Rainwater Tank is empty
(Float switch hangs vertically towards tank bottom)

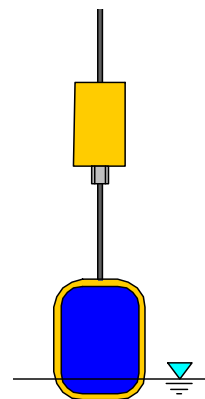







7.3.2 Maintenance mode (Switch position II)

The maintenance mode is selected by Switch position II. This mode is selected only when maintenance is to be performed in the tank. The RM Favorit-SC then operates in continuous mains water mode, independent of the float switch.

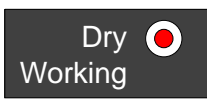

8. Safety monitoring and error notifications

N°	Alarm type with ALARM led ON	Protection	Description
A1		Current pick	The logic switches off the power instantaneously if this value exceeds a peak that can damage the power electronic components <ul style="list-style-type: none"> - high starting current - short-circuit on motor.
A2		Over-voltage	The logic switches off the current if the voltage exceeds a maximum instantaneous limit (+15%Vn)
A3		Minimum-voltage	If the voltage goes below the minimum value (-15%Vn) the power supply may provide a under-voltage to some electronic components; for this the logic switches off the current.
A4		Over-temperature IGBT	If the temperature of the power electronic components (IGBT) exceeds 85°C the inverter provide a thermal protection and stops the current. Before this stop protection the Inverter limit the current to 90% of the value imposed (F2)
A5		Motor Over-Current Thermal protection	To over-current beyond a certain time defined by an I ² t algorithm, the inverter limit the current to protect the motor from damage to the insulation. <i>For the correct functioning of this protection regulate the nominal motor current (F2).</i>
A6		Pressure transducer problem	In case of a problem or failure of the pressure transducer, the Inverter switches off the motor current. Re-start must be manually, pressing STOP followed by START.
A7		Minimum flow	This protection stop the pump when all output are closed and the flow of water is null. Do not appear "Alarm" led signalling
A8		Dry working	This protection stop the pump in absence of input flow of water. After five consecutive re-start, the stop is permanent and switch on also the "Alarm" led

All Alarms are showed with the corresponding Led on the circular LED indication and the red Alarm Led, that is flashing if the protection have automatic re-start otherwise is fixed if the protection need a manually re-start doing STOP then START.

Protections and Alarm details:

CURRENT PICK PROTECTION (A1):

The Inverter stop immediately the current in case this value exceed a maximum value limit for the electronic components





CLOSED DELIVERY WORKING PROTECTION (A7):

To prevent a closed delivery working, the control logic read the motor's working point condition; if this point is under a setting value, the system switches off the pump, and appears advise "Minimum Flow". At the end of this condition, the system restarts its normal operation. The pump curve is detected by the initial self-regulation check.

DRY WORKING PROTECTION (A8):

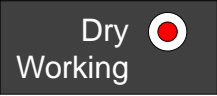
To avoid that the pump can continue to operate after a problem in absence of input water, the system read some information of the electric motor, in a time of 30 seconds, and when they go below a minimum, turn off the pump and show the relative signal of alarm "Dry Working". The inverter tries N°5 consecutive re-start in this condition, one spaced 15 minutes of each other. After the fifth consecutive fault, switch on the led Alarm and the re-start must be manually do, pressing STOP followed by START. ENABLE OFF: the enable contact (float contact) is open and the led MOTOR ON is flashing.

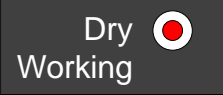
9. Trouble shooting in case of problems

Description of error	Cause	Solution
Pump is not starting: "Dry Working" illuminated "ALARM" not illuminated  	Motor stop for dry working condition of the pump, during one of four re-start of this problem, separated from 15 minutes. After the fourth unsuccessful restart, the installation goes into alarm mode.	Wait or Stop of the automatic Restart press bottom STOP. For starting the pump press bottom START
Pump is not starting and "Dry Working" illuminated and "Alarm" illuminated  	a.) Air in intake line, as float switch has not registered an empty tank and did not switch to mains water mode b.) Air in intake line because of a leakage c.) Non return valve in intake line leaky	a.) Check the functioning and position of the float switch (see chapter 6.6), After this new start up (see chapter 7) b.) Seal connection points and the intake line. After this new start up (see chapter 7) c.) Change non-return valve
Pump clocking or working for a long time only with low velocity in case of no consumer started	a.) Non-sealed leaky consumers b.) Minimal water flow (< 1 l/min) c.) Selected operating pressure too high d.) Settings changed or faulty	a.) Remove leakage b.) Check consumers c.) Minimise operating pressure (ideally 3 bar) d.) RESET and perform new self-initialization
In rainwater mode, the flow rate is too low or pump does not feed any water	a.) The intake filter is clogged b.) The intake hose is bent c.) The suction line or the lines are not sealed d.) no switchover to mains water since float switch is incorrectly positioned or is defective	a) clean intake filter b.) check intake line c.) check intake line and connections d.) check the functioning and position of the float switch (see chapter 6.3.4), then restart

Description of error	Cause	Solution
In mains water mode, the flow rate is too low or the pump does not feed any water	a) Not enough or no water in the units supplemental supply tank b.) 3/2-way ball valve does not switch over to mains water mode	a.) check primary pressure of mains water, clean filter sieve in the entry of supplemental supply valve (see chapter 5.3) b.) Change 3/2-way ball valve
System does not automatically switch from rainwater to mains water and vice versa.	a.) Float switch is not correctly positioned b.) Float switch is defective c.) 3/2-way ball valve does not switch over in spite of the float switch signal	a.) Check the functioning and position of the float switch (see Chapter 6.3.4), then restart or change float switch b.) Change float switch c.) Change 3/2-way ball valve

10. Maintenance

The *RM Favorit-SC* operates without requiring any maintenance. However, every six months the intake filter should be cleaned in the rainwater tank. The correct pre-print (2 bar) of the expansion tank should be proved every year.

11. Spare parts

Description	Figure no. (see chapter 4.1)	Order name
Multistage rotary pump for RMF-SC20	[1]	RMF-SC-P20
Multistage rotary pump for RMF-SC40	[1]	RMF-SC-P30
Basic-controller	[2]	RMF-SC-BPL
Pump-controller (speed control)	[5]	RMF-SC-PST
Pressure transducer	[6]	RMF-SC-DS
Supplemental supply container	[7]	RMF-B
Floating valve for supplemental supply container	[9]	RMF-NSP
3/2-way ball valve	[10]	RMF-KH
Float switch, 15m	without picture	RMF-SCHW15
Spare part for centrifugal pump		see Chapter 5.3

12. Optional Accessories

RAINMASTER D-24, Art.-Nr. 220092

The RAINMASTER D 24 is a fill level unit for water tanks up to 3 m water depth. It can be installed everywhere in the house and is a perfect complement for the RAINMASTER Favorit SC rainwater unit.



13. Guarantee

INTEWA GmbH guarantees this unit for 24 months from the date of purchase. Kindly keep the sales receipt as proof of purchase.

Within the guarantee period, INTEWA GmbH reserves the right to either repair or replace faulty parts at its own discretion.

The warranty does not cover any damage due to improper use, wear and tear, or intervention by third parties. The warranty does not cover any defects which may only minutely affect the value or usability of the device.

14. Contact / unit serial number

For customers in Germany:

For any queries, ordering of spare parts, as well as in case of service, kindly contact INTEWA GmbH directly, quoting your product's model and identification numbers and the purchase invoice details, at:

INTEWA GmbH
Jülicher Straße 336
52070 Aachen

Tel.: 0049-241-96605-0
Fax: 0049-241-96605-10
Email: info@intewa.de
Internet: www.intewa.de

For customers in other countries:

For any queries, ordering of spare parts, as well as in case of service, kindly contact your installer or the authorised importer, quoting your product's model and identification numbers, and the purchase invoice details.

Your RAINMASTER Favorit-SC identification number is displayed on the right hand top side of the mains water tank. The unit housing must be removed to see this.

Annex 1.0 Scope of duplex or triplex application

For larger commercial applications, where pumping reliability and consistency is a must, the speed-controlled *RM Favorit SC* models are used to ensure water is always efficiently and reliably delivered to the required application. Up to three *RM Favorit SC* units can be connected in parallel, as a powerful multiple pumping system.

The units communicate together via Bluetooth. In this configuration, should one pump ever fail, the others simply take on the load. Through Bluetooth the automatic, bidirectional start-up of the pumps, the peak load connection and the operating pressure settings are aligned and transferred wirelessly. Slave and Master functions are automatically transferred to the operating units in the event of an equipment malfunction.

Annex 1.1 Intake variants

When using duplex or triplex *RM Favorit SC* units in parallel, you have the option of a central 1 ½" intake INTEWA SAGF 1 ½" from the tank or to connect to any single device with a 1" intake (INTEWA SAGF 1".) If the intake line is longer, and/or the intake height higher, than the recommended pump specifications, then a hybrid container must be used in order to increase the parameters of the pumping system. The hybrid container supplied from the main tank by the charging pump.

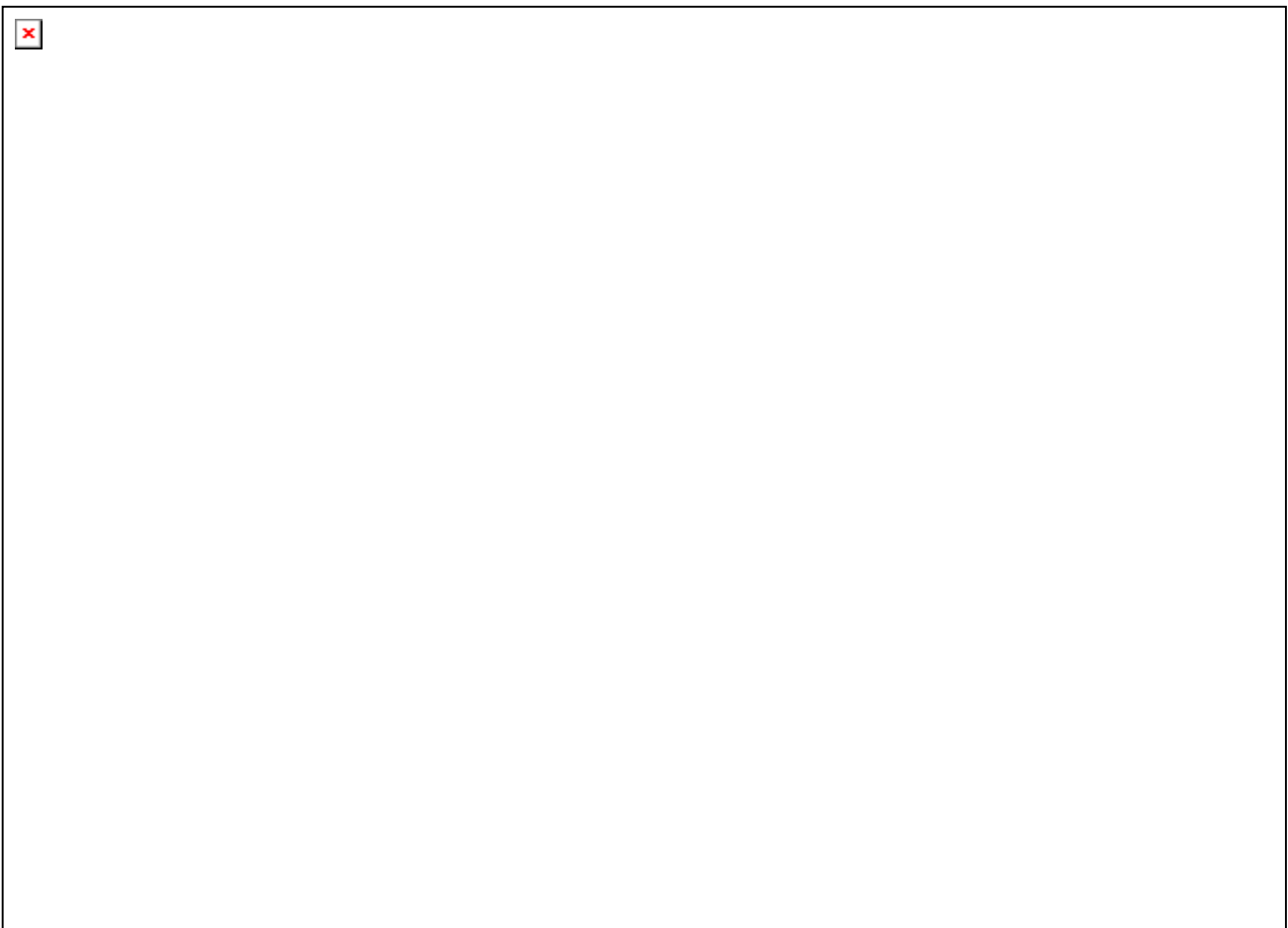

Sample overview of a rainwater harvesting system using three (triplex) *RM Favorit SC* units connected in parallel.

Legend:

- | | |
|--|---|
| 1: RAINMASTER Favorit Rainwater system | 10: Emergency overflow hybrid tank |
| 2: Mains water connection | 11: Float switch mains water |
| 3: Pressure line set | 12: Float switch charging pump |
| 4: Expansion tank | 13: Protective conduit for intake line and sensor cable |
| 5: Pressure line to consumers | 14: Rainwater inlet pipe |
| 6: Cable of float switch for switch to mains water | 15: PURAIN Rainwater filter |
| 7: Central intake lin with SAGF 1 1/2" | 16: Charging pump |
| 8: Emergency overflow | 17: Float switch protection against dry running charging pump |
| 9: RMF-SC Hybrid | |

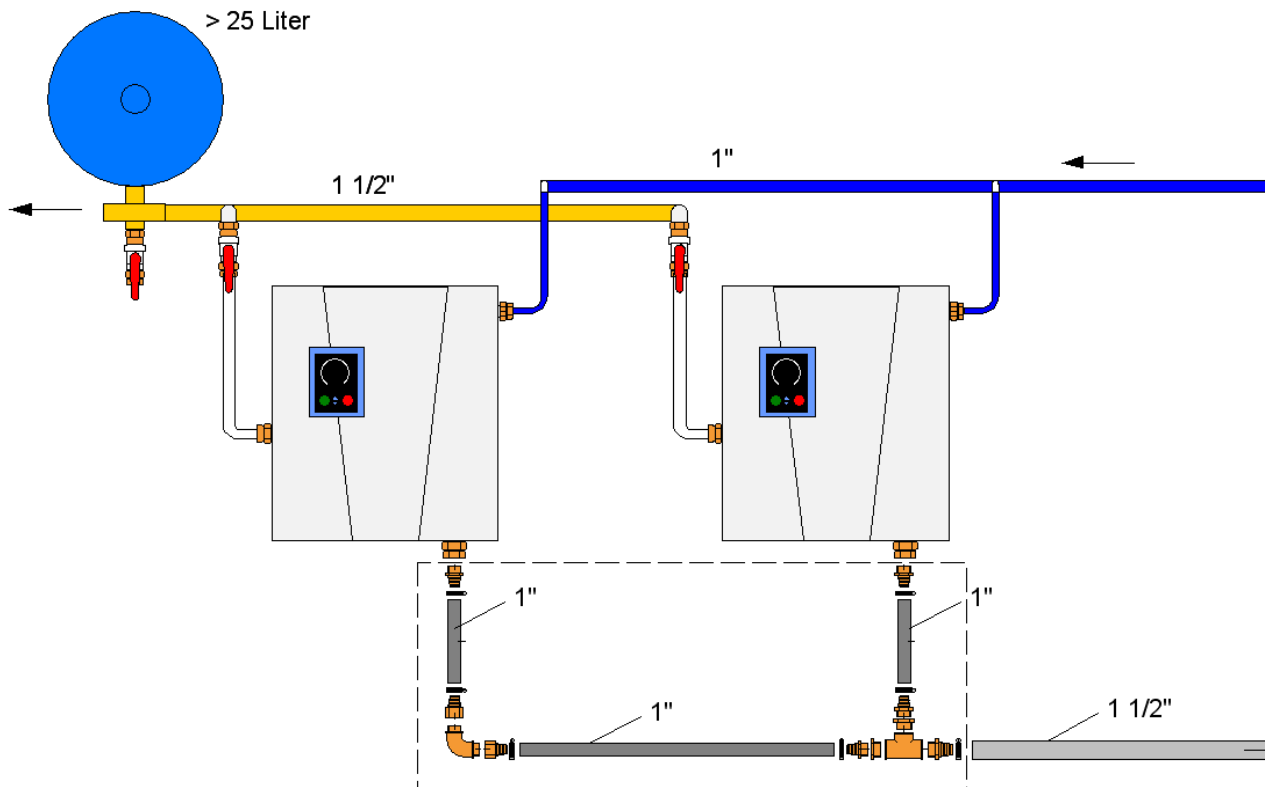

Picture connection fittings intake filter SaugSAGF 1 1/2 inch



Attention:

In the main storage or in the hybrid storage tank the floating switches for the mains water are installed. The float switch must not be connected in parallel. Each device must be connected via its own float switch!

Annex 1.2 Technical data for duplex- and triplex-application

All pipes must be sized according to the maximum flow rate.

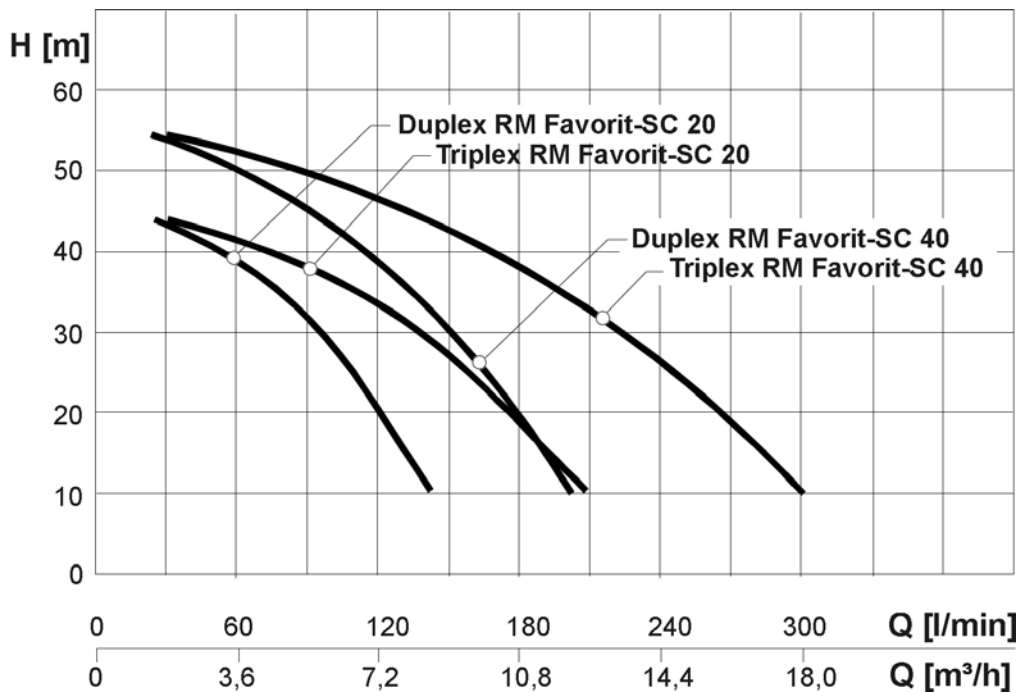

Performance curve of RMF-SC Duplex- und RMF-SC Triplex

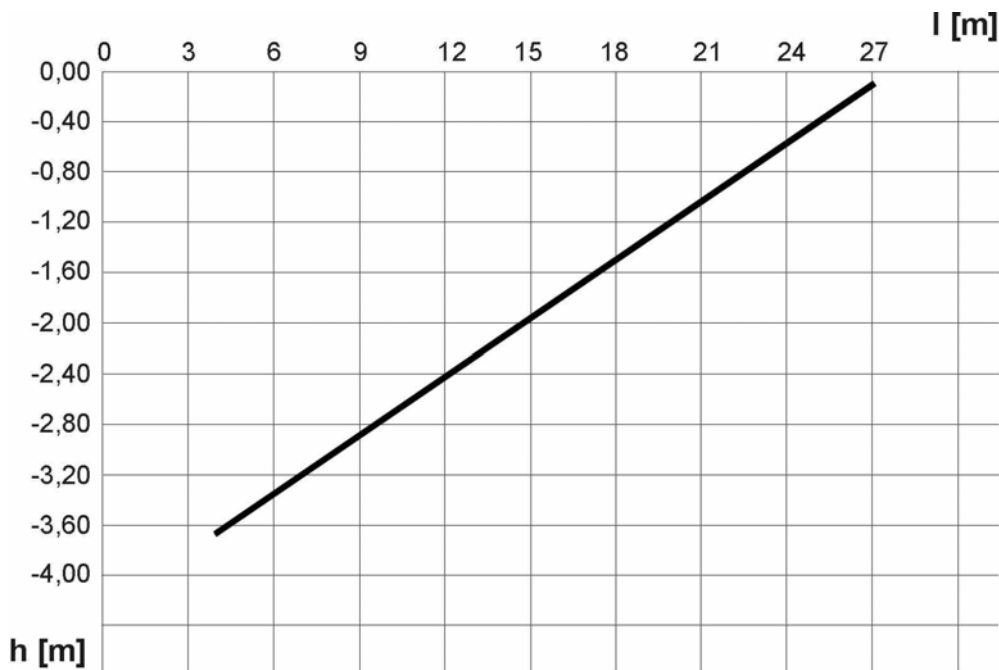



Performance curve of the intake of RMF-SC Duplex- und Triplex with 1 1/2" intake line

We suggest following sizing of a central pipe system:

	Pressure line	Mains water line	Intake line
Duplex RM Favorit-SC 20/40 Triplex RM Favorit-SC 20/40	1 1/2"	1"	1 1/2"

Annex 1.3 Group function via Bluetooth by duplex and triplex applications

1. Each RM Favorit SC unit is factory initialized, allowing pre-set operation procedures to occur. Is it still necessary to perform a self-initialization. (E.g. after a RESET), than every device has to be initialized individually.
2. In order to initiate a Bluetooth connection, the mains plug of all RMF-SC's must be inserted within 10 seconds of each other (all LEDs must be extinguished beforehand).
All Power LED's flash simultaneously when the connection with all units is obtained. This procedure lasts for approx. 20 seconds.
3. The systems are now ready to use. The pump will automatically start as soon as a decrease in pressure is detected.
4. The desired operating pressure can be adjusted by pressing  or  on any one pump controller. (The Bluetooth connection automatically transfers these settings to the other devices).

Note:

It is necessary for the *RMF-SC* to execute a fresh automatic initialization after every RESET (see Chapter 5.1.3). It is important that the other parallel connected *RMF-SC*'s remain plugged in with Power ON, in order that all units initialize successfully together via Bluetooth.

If there are several devices in the room that operate independent of each other, then the transfer frequency can be modified (see Setting F20, Chapter 5.1.4). If a pump alone runs for 30 seconds, then the pump control is determined to be "single mode" (F17-3). The Group function can then be setup, in which F17 is modified.

