

INTEWA

INTEWA PRODUCTS



INTEWA DRAINMAX® Tunnel

- DM-T- /6o (DIBt)
- DM-T-/12

Technical documentation and application



WATER, WE'RE IN OUR ELEMENT

Table of contents

1	Introduction	2
1.1	Range of application	3
2	Product description	4
2.1	Technical Data	6
2.2	Transportation and mounting	8
3	Instructions for layout, planning and execution of infiltration and retentions systems	9
3.1	Instructions for layout	9
3.2	Instructions for pre-treatment of rainwater	10
3.3	Instructions for inspection and cleaning devices	11
3.4	Instructions for pipe installation and ventilation of system	12
4	Installation instructions	15
4.1	Base layer and equalizing layer	15
4.2	Backfilling materials and backfilling of the tunnel system	15
4.2.1	Backfilling with non-binding material	16
4.2.2	Backfilling with 16/32 mm gravel	17
4.3	Covering and load bearing capacity of the tunnel system	18
4.3.1	DRAINMAX Tunnel/60 with DIBt approval	18
4.3.2	DRAINMAX Tunnel/12	18
4.3.3	Object-specific calculation for special edge condition	19
4.4	Overview of construction with paved traffic areas as per RStO 01	19
4.5	Load capacity during installation	20
4.6	Woven filter fabric at the base of the tunnel	22
4.7	Filter fabric cover	23
5	Overview of installation steps	24
6	Service	26
6.1	Inspection and Maintenance	26
6.2	References	27
6.3	Warranty and manufacturer's guarantees	27

1 Introduction

Infiltration and attenuation of rain water has increasingly become the focus of public interest in past few years. Floods, falling ground water level as well as overloaded and outdated sewer systems in many regions has led to an increased importance of local water management system.

Increasing environmental awareness of the natural infiltration of rainwater and economic constraints in many states has accordingly led to numerous government regulations and amendments for local rainwater management.

- In NRW, the state water law requires infiltration of rain water on the grounds of new buildings
- In several countries and municipalities, the subsequent installation of local water management systems is required.
- In a large number of municipalities, a fee has to be paid due to the sealed surface in order to increase the incentive for local infiltration.

If a local infiltration rainwater is not possible, then in several cases, the temporary attenuation (retention) of rainwater is necessary in attenuation areas. It is protected against overloading by means of a throttled discharge into the connecting drainage system or it is constructed with a smaller size.

The advantages of local rainwater management for municipalities are:

- Reduced expenditure on flood protection / flood prevention
- lower costs in construction of drainage system, the drainage rehabilitation and in using treatment plant
- Less development of costs for new housing areas
- Provision of basic water supply

As manufacturers, the INTEWA GmbH has specially developed the DRAINMAX® tunnel system for infiltration, attenuation and storage of rainwater. The tunnel system built underground minimizes the expenses for creation and operation of the rainwater management system. Due to its flexibility, the DRAINMAX® tunnel system is used as a solution for drainage of rainwater ranging from individual buildings to large commercial properties.

This documentation serves as the base for the production engineers and fabricators alike. As long as the fabricator complies with the below mentioned installation guideline, then maximum service life and safety of the system is guaranteed.

This documentation corresponds with the current state of technology, but makes no claim to complete. Technical changes are also reserved.

1.1 Range of application

The INTEWA DRAINMAX® tunnel system is specially designed for underground infiltration, attenuation and storage of rainwater. The system can be used alike in small drainage tasks up to huge applications in commercial and industrial sectors.

Using the tunnel system for trench infiltration

The rainwater infiltration allows infiltration of rainwater at source.

Some of the advantages of infiltration are:

- The rainwater is recycled back into the natural water cycle
- Decoupling from the drainage system and thereby exemption from the fee due to sealing charged in several places

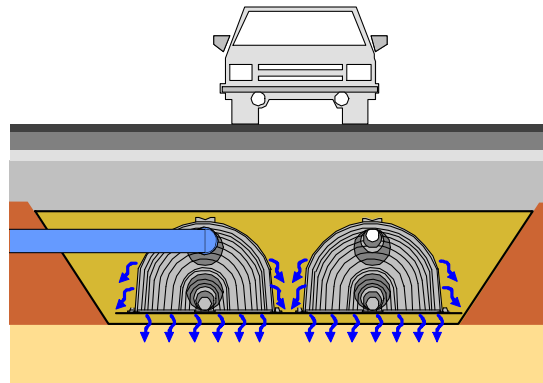

Fig. 1: Trench infiltration

Using the tunnel system for pit - trench infiltration

As a general rule, the combination of pit infiltration and trench infiltration is done when:

- an infiltration is required by the so-called busy ground zone
- the space required for a commercial pit has to be minimized

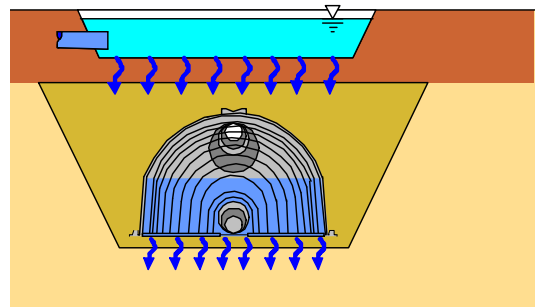

Fig. 2: Pit – trench infiltration

Using the tunnel system for rainwater attenuation

With attenuation, the rain water is temporarily stored in the tunnel system and is throttled via a special drainage device to the drainage system.

Reasons for attenuation may include:

- Connecting additional sealed surfaces to existing drainage systems
- Municipality order, for example, if the local soil conditions do not allow infiltration
- Reduction of peak drainage flows in the drainage system during heavy rainfalls

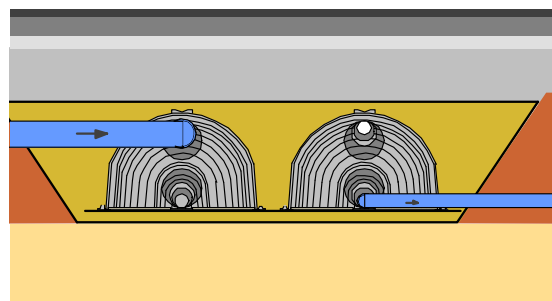

Fig. 3: Rainwater attenuation

2 Product description

The INTEWA DRAINMAX[®] system elements are designed for underground installation. The rainwater is directed into the created underground storage reservoir for infiltration or temporary storage.

The load of earth and transportation is directed into the surrounding ground soil due to the vault-shaped design of the INTEWA DRAINMAX[®] tunnel. The prerequisite load bearing capacity is the loading of tunnel body on to the ground by backfilling sides.

The DRAINMAX[®] tunnel can be used below traffic zone with heavy load up to SLW60 depending on the type of backfilling (gravel or consolidated soil material) and the amount of cover. The height above ground can be lie within the range from 50 to 200 cm above the tunnel shoulder (Chap. 4.6).

The water is uniformly divided and infiltrated in the ground without any obstructions by means of the completely open interior of the tunnel. The boring rows on both sides for two height levels ensure infiltration even from the potentially necessary infiltration from sides.

The INTEWA DRAINMAX[®] system elements are:

- Start section (with 4 cm small connecting serrations)
- Central tunnel (on one side with an 8 cm wide connecting serration and on the other side with a 4 cm small connecting serration)
- End section (with an 8 cm wide connecting serration)

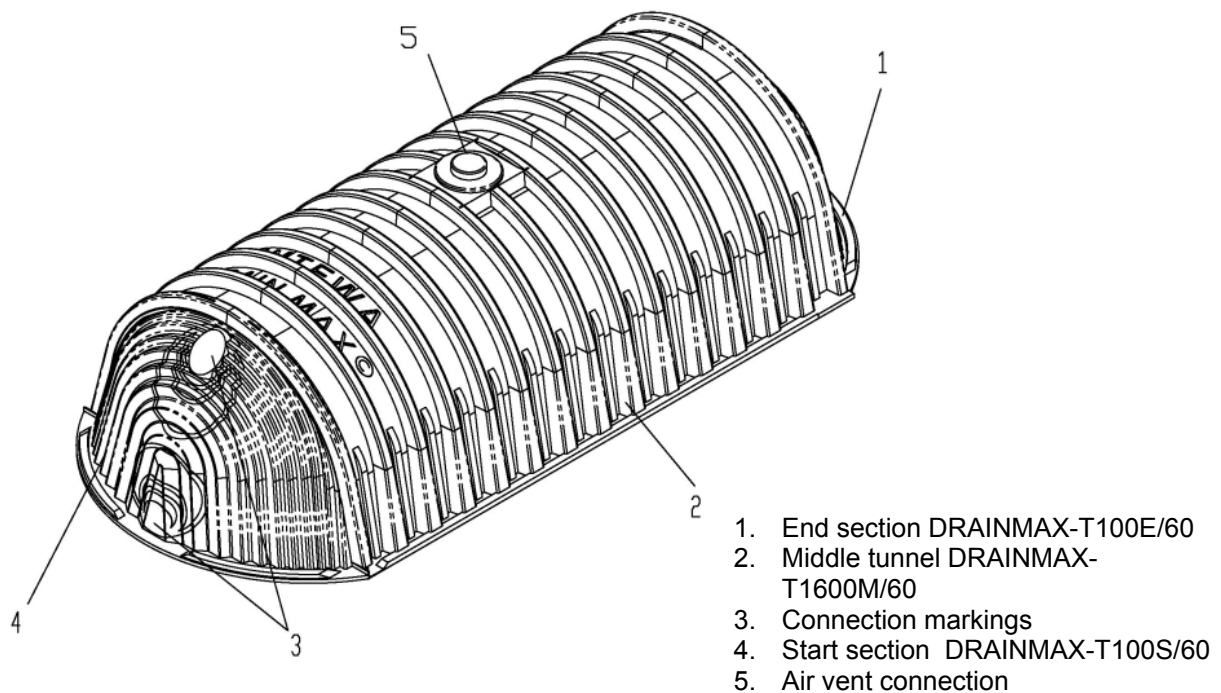

Fig. 4: DRAINMAX Tunnel

The INTEWA DRAINMAX[®] tunnel elements are manually laid in rows. A distance of 450 mm must be maintained with a parallel installation of rows.

The elements of start section, the middle tunnel and the end section are added together in a row and a closed system is provided by the connecting serrations overlapping and fitting each other with face-up position.

The connecting pipes for water intake and discharge as well as for evacuating the air are installed at the start and end section of the tunnel row. You can install a pipeline connection ranging from DN100 to DN300 in both lower and upper region.

The DRAINMAX[®] tunnel elements must be installed as per the installation guidelines mentioned below. The DRAINMAX[®] tunnel elements are then laid for a service life of 50 years with respect to their material characteristics and their scope of use.

The installation varieties other than these need a separate structural calculation.

The elements are made from polyethylene (PE-HD) with cupping process. This technical plastic is resistant to chemicals and microorganisms and thus does not rot. The variety of pure plastic is also 100 % recyclable.



Warning instructions:

- The tunnel elements may not be committed from within.
- The following installation guidelines are crucial for installation.
- The tunnel elements may not run over by site vehicles just after a consolidated minimum covering.
- The specific planning specifications are to be observed.

2.1 Technical Data

	Middle tunnel	Start section	End section
DRAINMAX parts	DM-T-1600-M/60 DM-T-1600-M/12	DM-T-100-S/60 DM-T-100-S/12	DM-T-100-E/60 DM-T-100-E/12
Length	2340 mm	443 mm	444 mm
Width	1375 mm	1375 mm	1375 mm
Height (corrugated shoulder)	781 mm	767 mm	736 mm
Height (Dome connection)	805 mm	--	--
effective used length	2250 mm	--	--
Load class DM-T-/60	HGV60	HGV60	HGV60
Load class DM-T-/12	12 t Lorry	12 t Lorry	12 t Lorry
Weight DM-T-/60	32 kg	5,5 kg	5,6 kg
Weight DM-T-/12	26 kg	4,5 kg	4,6 kg
Material	PE-HD	PE-HD	PE-HD
Connections	1 x DN100 (Dome)	DN100-300	DN100-300
Approved tolerance	± 4 %	± 4 %	± 4 %
Approved processing temperature	+2 to + 30°C	+2 to + 30°C	+2 to + 30°C
Storage volume	1,6 m ³	0,1 m ³	0,1 m ³

Tab. 1: Technical data of the DRAINMAX[®] tunnel elements

Note:

For quick visual identification the different tunnel configurations labeled with following colors:

- DM-T- /60 = green
- DM-T- /12 = blue



Fig. 4a: Example for DRAINMAX Tunnel DM-T/60 with green sprayed strip

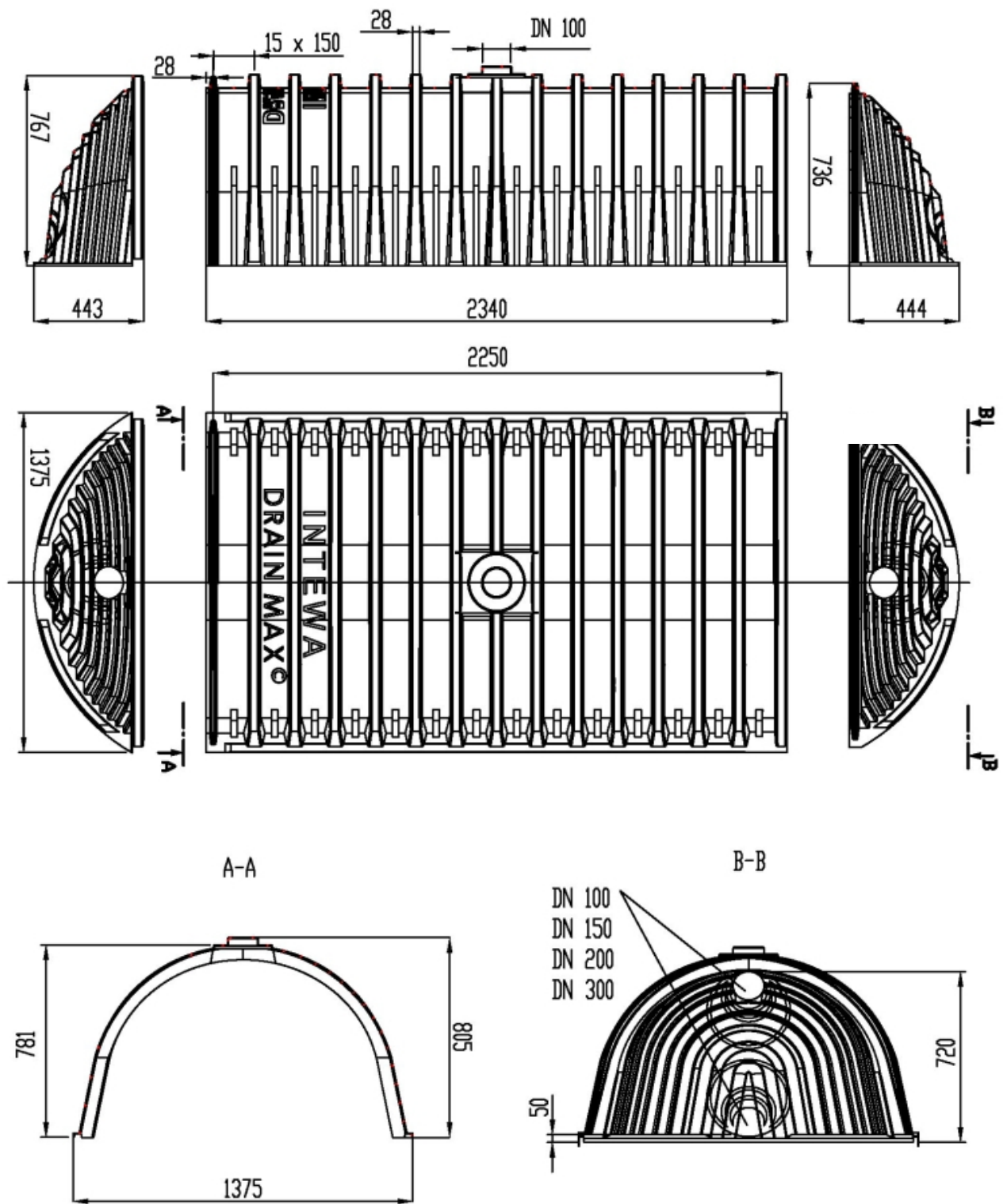

Fig. 5: Dimensions of the DRAINMAX® tunnel elements and connection markings

2.2 Transportation and mounting

The elements of DRAINMAX® Tunnel are packed on pallets or delivered as packaged goods to the site. There on site, they are unloaded manually, lifting truck or other lifting aids. The starts section and end section generally transported below the middle tunnels.



Image 1: Pallet transportation of the Tunnel elements Image 2: Lifting the elements

The temporary storage must be done on the special delivery pallets. With risk of high winds, the piled tunnel elements must be secured with straps.

The DRAINMAX® Tunnel can be stored outdoors. But then you have to protect them from direct sunlight and heat by using a bright, opaque covering. The storage time should not exceed one year.



Warning

The tunnel elements may be damaged due to inappropriate handling. The impact load is to be avoided particularly in cold weather.

	Palett	Lorry 40 t, Trailer truck	45 FT HC Container (Ocean freight)
Dimensions (L x W x H)	2,34 x 1,40 x 2,20 m	13,6 x 2,46 x 2,55 m	13,56 x 2,35 x 2,70 m
max. Number of pieces	20 Tunnel = 1 palett*	180 Tunnel = 9 pallets	225 Tunnel = 9 pallets*
Loading weight of max. Number of pieces DM-T-1600-M/60	690 kg	6210 kg	7650 kg
Loading weight of max. Number of pieces DM-T-1600-M/60	540 kg	4860 kg	6030 kg
Gross storage volume (without sections)	32 m ³	288 m ³	360 m ³

*In maximum 5 start- and 5 end sections can packed together with each pallet

Tab. 2: Transportation dimensions and weight of DRAINMAX Tunnels

3 Instructions for layout, planning and execution of infiltration and re-tentions systems

The knowledge of local geological and hydrological conditions which can be examined by experts must be known. The infiltration area has to be examined with respect to the type of soil, ground water condition (even in terms of increased ground water as a result of infiltration) as well as permeability and stability by the Geotechnical Engineer especially with infiltration systems.

Moreover, following legal regulations and technical directives have to be observed for the construction of rainwater management systems:

Legal regulations	Technical directives
<ul style="list-style-type: none">- EU-law- Federal law- Federal State Law- Municipal Statutory Law	<ul style="list-style-type: none">- Work Sheet DWA-A 138- ATV-DVWK-M 153- DWA-A117, A118, A121, A128- KOSTRA- Various standards: including DIN4261-1, EN 752

Tab. 3: Overview of legal regulations and technical directives

Technical and construction restrictions related to drainage water technology are to be inquired to the responsible authorities.

3.1 Instructions for layout

The layout of the rainwater management systems usually includes the steps listed below:

- Inventory control and assessment of the connected, fixed surfaces
- Calculating the amount of inflow as well as infiltration and attenuation system
- Calculation of infiltration runoff (the runoff with attenuation system will be firmly defined by the specified throttle runoff value)
- Iterative determination of the required storage volume depending on the local rainfall and frequency of overflow events
- Assessment and selection of the most economical system design
- Specifying the design: The number of tunnel and arrangement, type of backfilling material
- If necessary, determining the pre-cleaning measures, flushing and inspection chambers, mounting material, etc.

The INTEWA GmbH will gladly support you with planning and design. This also includes support for hydraulic proof by software – supported simulation.

3.2 Instructions for pre-treatment of rainwater

The water supplied by DRAINMAX® system requires a sedimentation and filtration in order to ensure the proper functioning of the infiltration system or the attenuation system.

Regular inspections, maintenance and cleaning by this pre-treatment fixtures ensure a smooth operation of the tunnel system primarily with respect to a uniform infiltration performance and the protection of the throttle device with the attenuation systems.

For infiltration systems, the sizing and selection of water pre-treatment fixtures also emphasises more on the expected concentration of material and thereby if necessary, associated hazards of groundwater.

The load of underground water and above ground water can be evaluated qualitatively and quantitatively with the help of simple evaluation methods by rain water from roofs and traffic zones. (The appendix A to C of the ATV-M153 allows a full and detailed assessment of pre-cleaning measures.)

Depending on the result and various measures for rainwater treatment, a sufficient protection of water has to be ensured. The INTEWA GmbH will gladly support you with planning and design.

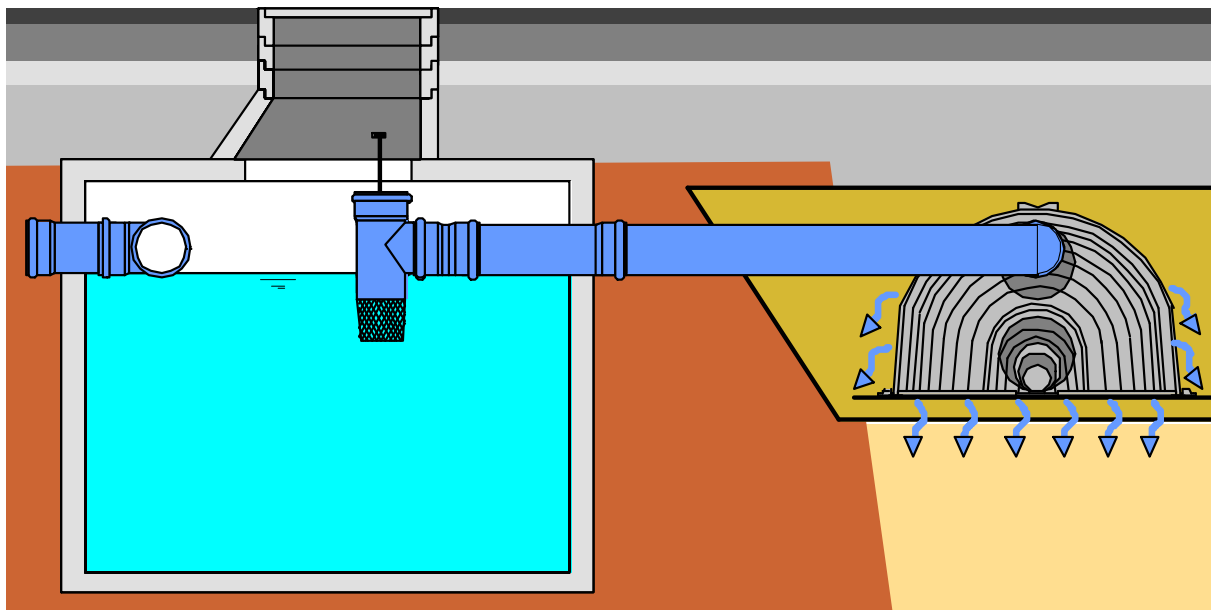

Fig. 6: Example: Sedimentations slot and filter slot for cleaning rainwater

3.3 Instructions for inspection and cleaning devices

You can inspect it fully due to the fully open half-shell design of the tunnel element and if necessary, it can also be cleaned. You just have to connect the row of flushing tunnel to a flushing chamber and inspection chamber. From here, you can direct a rotary – swiveling camera or cleaning nozzle in the system and the dirt can be removed from the system.

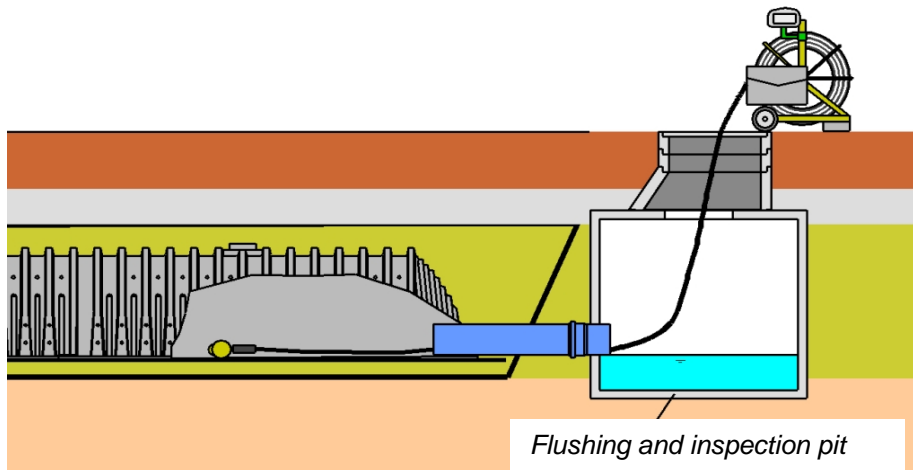

Fig. 7: Camera inspection by the inspection pit entrance

Due to well-sized application of the preliminary sedimentation system, usually a regular cleaning of the infiltration trench is not required. However, you can carry out clean in case of emergency with appropriate precautionary measures such as arrangement and the number of flushing and inspections chambers as well as the special layout of the flushing tunnel row are to be taken into consideration in the planning phase.

Generally, cleaning is done only when it is recommended in an inspection report that too much sedimentation has been deposited or if the infiltration capacity is reduced significantly.

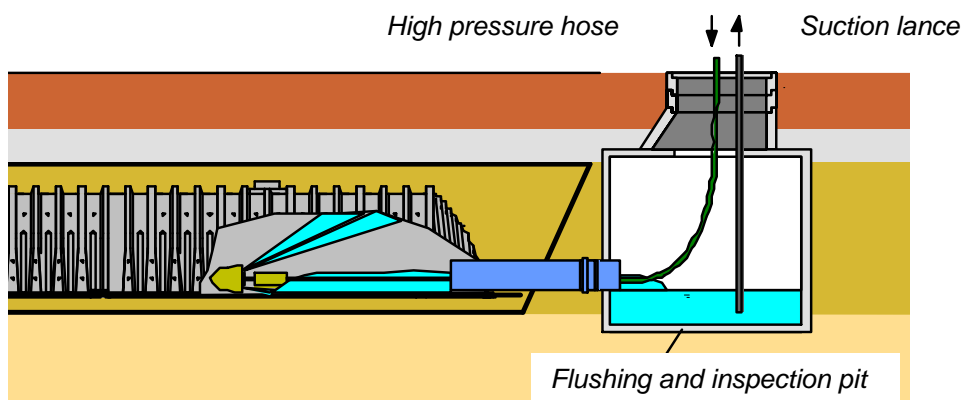

Fig. 8: Cleaning and slime removal via flushing and inspection pit

Then the bottom of the tunnel is cleaned by means of a high pressure cleaning nozzle in the tunnel row deployed as the flushing tunnel. The cleaning nozzle of the flushing truck is directed towards the flushing and inspection pit in the flushing tunnel. The reverse jet of the cleaning nozzle cleans the sedimentation settled at the bottom of the flushing pit and inspection chamber which is from here sucked through suction lance. Several cleaning and rinsing cycles may be required depending upon the dirt.



Image 3: Flushing nozzle with reverse conical jets



Image 4: Flushing nozzle with cleaning procedure

3.4 Instructions for pipe installation and ventilation of system

The pipes are connected as per the specifications in plan from the head end of the tunnel to the start and end sections. The pipe connection markings at the tunnel section allow on-site cutting by means of a sabre saw. The inlet pipe of the rainwater into the tunnel system can be introduced at the level of tunnel shoulder or tunnel bottom.

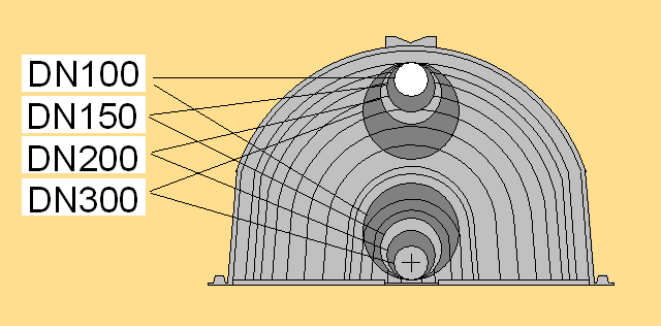

Fig. 9: Connection markings of the start and end section

The inflow into each row of tunnel is usually done at the pre-cleaning fixture via an appropriately connected piping system. In case of several rows, the volume flow rate of inflow is equally distributed in all rows of tunnels.

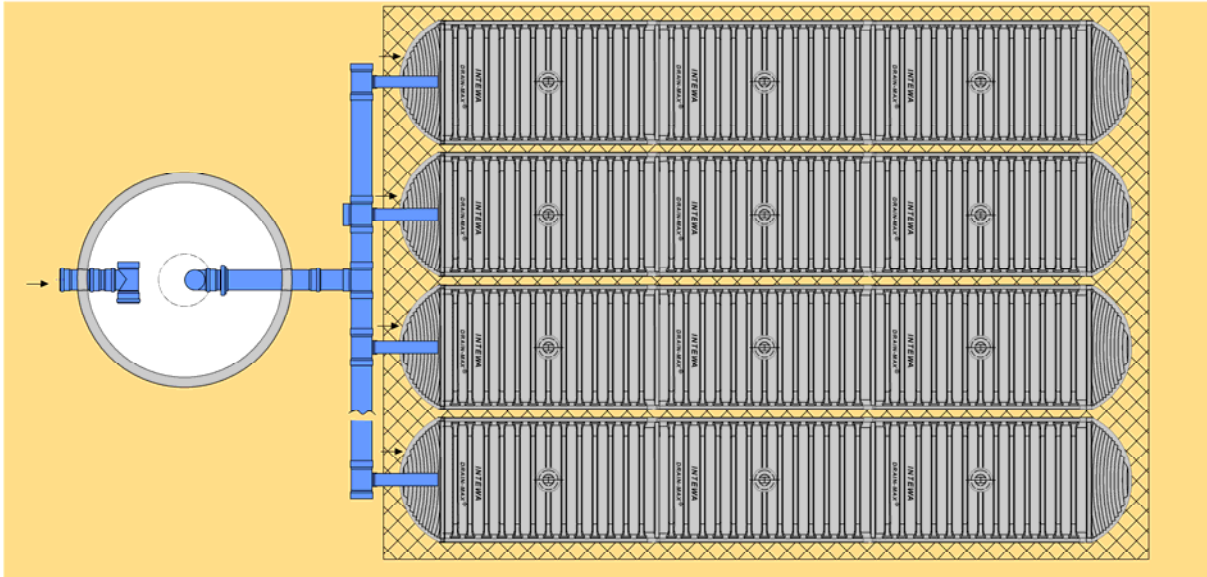

Fig. 10: Example for connected piping system to the preliminary sedimentation and filter pit

If a flushing tunnel is used, the water is distributed at the end of flushing tunnel row into parallel tunnel rows.

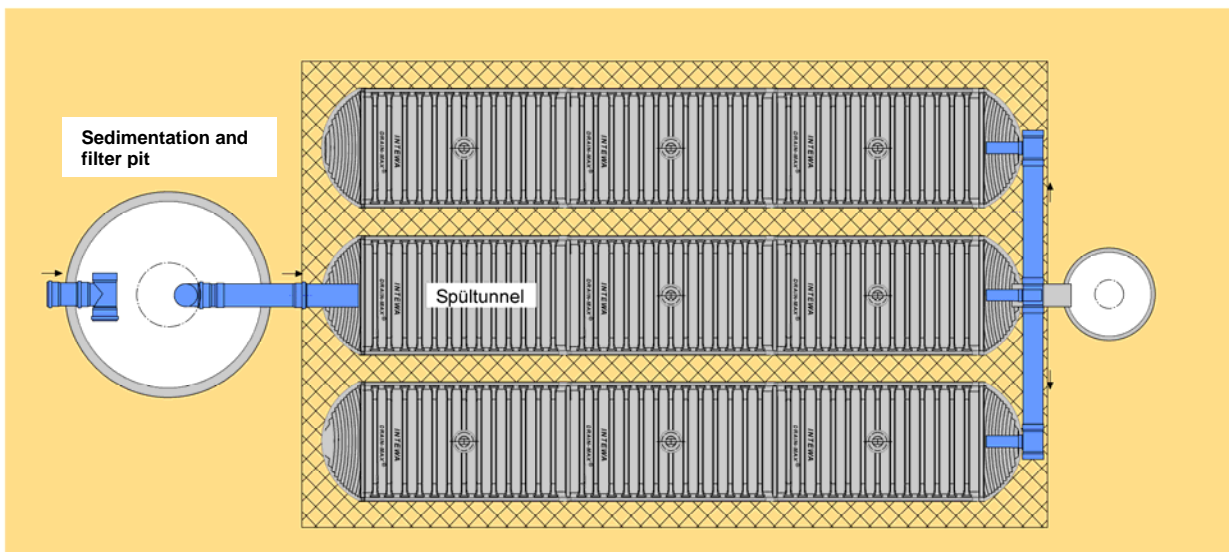
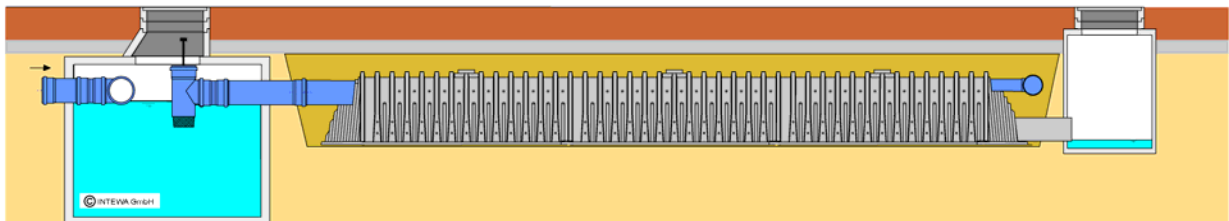

Fig.11: Example for inflow connection of the parallel tunnel rows by using a flushing tunnel

The variations in air pressure caused in the tunnel system by inflow and discharge of the water must be balanced by ventilation. The size of vent is based on the maximum volume flow rate of inflow. A venting connection is provided in DN100 depending on the inflow amount 20 l/s.

The venting connection from tunnel is done from the centre of tunnel dome or from the top of section connection. The air is transferred outside via a vent of air to the outside via a ventilated pit (such as, sedimentation pit or flushing and inspection pit).

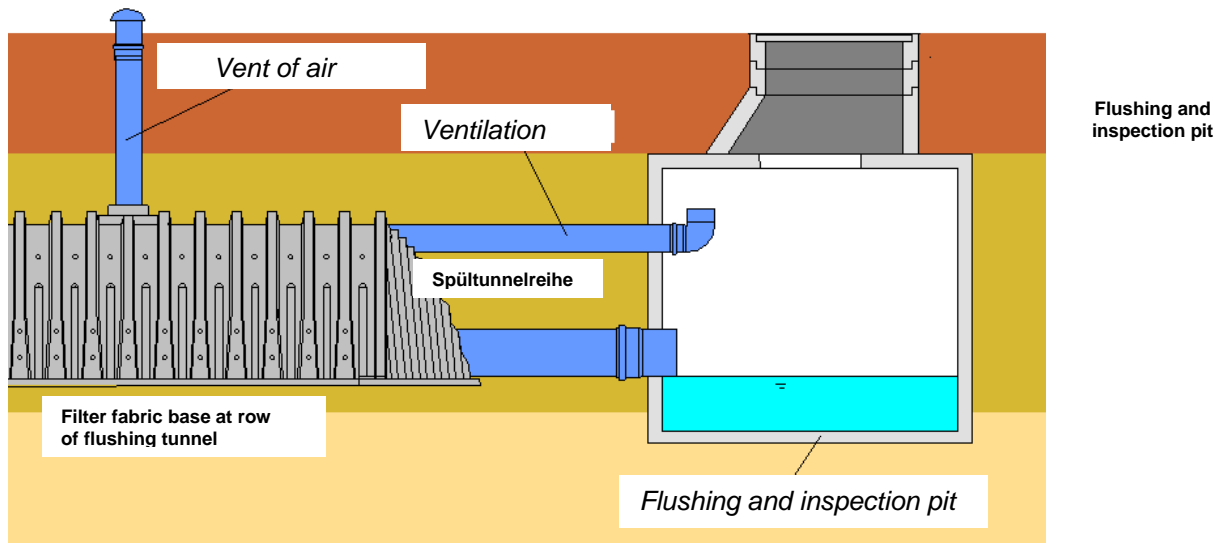

Fig. 12: Example for venting possibility

4 Installation instructions

The professional installation of the tunnel elements is a prerequisite for proper functioning and long service life of the entire system. This affects the entire construction phases right from the preparation of plan to backfilling up till the covering of the tunnel system.

4.1 Base layer and equalizing layer

The load bearing capacity of the existing soil is necessary for obtaining the stability of the tunnel system. If there is lack of knowledge or doubt related to the load bearing capacity of the soil, then a special investigation is necessary by a Geotechnical Engineer. If the load bearing capacity of natural soil is not sufficient, then if necessary, the required load bearing capacity can be established by advanced measures (for example, gravel base layer, filter fabric insert etc.).

A non-binding, consolidating soil material may be used as a base layer cannot cohesive, compressible soil material can be used up till gravels with a grain size up to 16/32 mm. The contact patch of the tunnel must indicate a load bearing capacity of at least $E_{v2} \geq 45 \text{ MN/m}^2$.

For infiltration purposes, the permeability of the consolidated underground soil must at least correspond with the permeability as specified in the plan.

4.2 Backfilling materials and backfilling of the tunnel system

The tunnel system can be backfilled with a permeable, non-binding and consolidating soil material up to 16/32 mm gravel, depending on the required load bearing capacity of the entire system. Generally, the tunnel system can be loaded with a consolidated backfilling with at the highest.

Attention

Regardless of the backfilling material, the backfilling is even and on both sides in layers of 20 cm.

One sided backfilling is not permitted, since this can lead ti deformation of the tunnel structure and minimizes the capacity of the system.

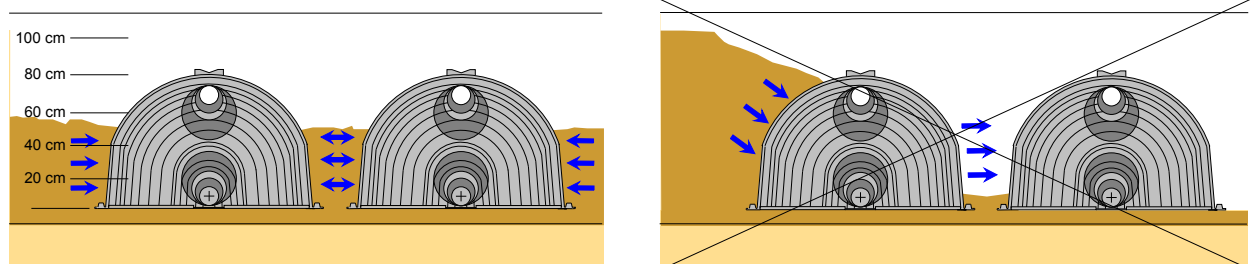

Fig. 13: not permitted, one sided backfilling

4.2.1 Backfilling with non-binding material

If the backfilling is to be done with non-binding backfilling material with fells, then the tunnel elements must be directly covered with a GRK 5 filter fabric in order to prevent the penetration of fells into the infiltration holes on sides.

The minimum cover above the tunnel shoulder is specified as fixed 35 cm. Hereby, the load bearing capacity $E_{v2} = 45\text{MN/m}^2$ required for track superstructure as per RSTO 01 is to be established.

The backfilling from sides and top occurs in layers with max. 20 cm with appropriate consolidation. (The compacting requirements of ZTV E-StB 09 are to be observed under traffic zones over traffic areas of compaction requirements are noted ZTV E-StB 09)

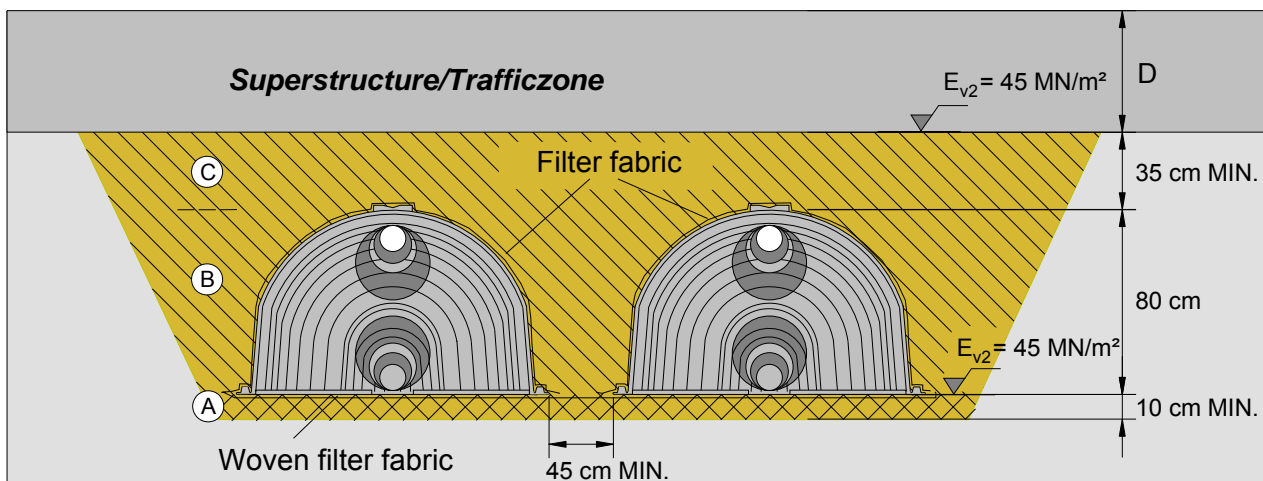

Notice: The allowed minimal and maximum height D is addicted by the installation situation and traffic load (Chap. 4.3)

Fig. 14: backfilling with non-binding, consolidating soil material

The backfilling material as well the required load bearing capacities of the construction layer are to be referred from the following table.

Construction layer		Material	Load bearing capacity
A, C	Base and equalizing layer	Non-binding, consolidating material with soil class 3 and 4 as per DIN 18196	$D_{pr} \geq 97\%$ min. $E_{v2} = 45\text{MN/m}^2$
B	Backfilling of tunnel from sides and top	Non-binding, consolidating material as per DIN 18196 (consolidation of up to 20 cm each)	$D_{pr} \geq 97\%$
C	Tunnel covering	Non-binding, consolidating material as per DIN 18196 (consolidation of up to 20 cm each)	$D_{pr} \geq 97\%$ min. $E_{v2} = 45\text{MN/m}^2$

Tab. 4: Construction layers with backfilling tunnel using non-binding material

4.2.2 Backfilling with 16/32 mm gravel

The backfilling with gravel is a kind of construction for creating additional infiltration volume by void proportion of the gravel. The characteristics related to installation of filter fabric and establishing traceable load bearing capacity is to be observed with backfilling.

The direct covering of tunnel rows with filter fabric is not mandatory with 16/32 mm gravel, since as this size of particles cannot enter through the side holes. In order to prevent the submerging of surrounding soil into the gravel bed, it is necessary to cover it with filter fabric from all sides. For obtaining the required load bearing capacity of $E_{V2} = 45\text{MN/m}^2$, a consolidated layer of at least 25 cm must be introduced with non-binding and consolidated material on 10 cm tunnel cover. A plane intermediate layer of filter fabric protects the gravel bed from penetration of fells.

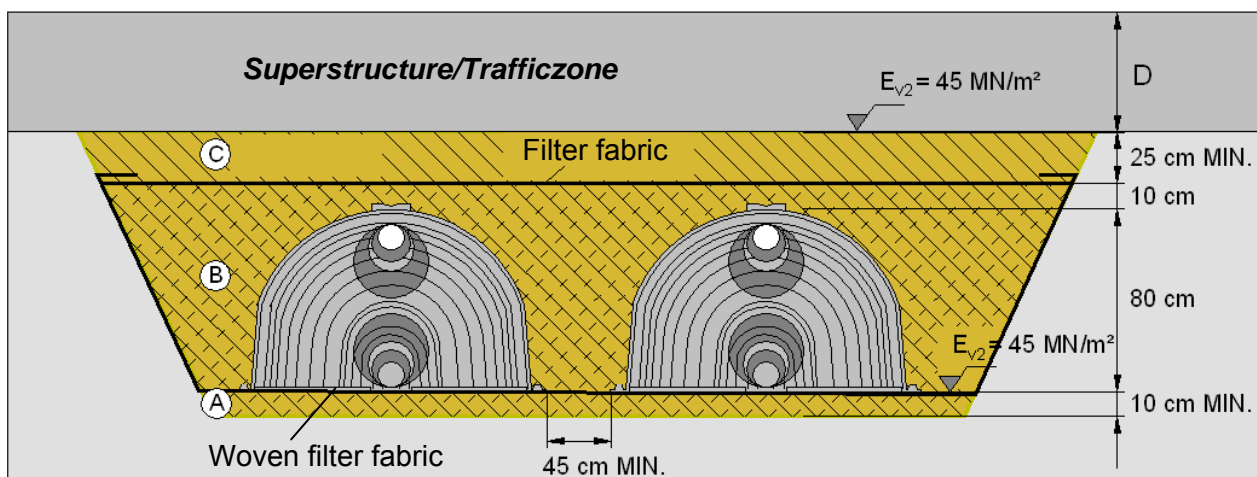

Notice: The allowed minimal and maximum height D is addicted by the installation situation and traffic load (Chap. 4.3)

Fig. 15: Construction layers with tunnel backfilling using 16/32 gravel (SLW30 congestion)

The backfilling material as well the required load bearing capacities of the construction layer are to be referred from the following table.

Construction layer		Material	Load bearing capacity
A	Base and equalizing layer	Non-binding, consolidating material As per DIN 18196	min. $E_{V2} = 45\text{MN/m}^2$ $D_{pr} \geq 97\%$
B	Tunnel backfilling from sides and top (≥ 10 cm)	Crushed gravel 16/32 mm gravel	$D_{pr} \geq 97\%$
C	Tunnel covering (≥ 25 cm)	<i>With firm surfaces:</i> Non-binding, consolidating material As per DIN 18196	$D_{pr} \geq 97\%$ min. $E_{V2} = 45\text{MN/m}^2$
C*	Tunnel covering	<i>With loose surfaces (such as pit – trench infiltration):</i> Ground with permeability requirements as per DWA-A138 $K_f \geq 1 \times 10^{-4}$ m/s	Low consolidating installation max. $D_{pr} = 92\%$

Tab. 5: Construction layers with backfilling using 16/32 gravel

4.3 Covering and load bearing capacity of the tunnel system

The load bearing capacity of the installed tunnel system is in addition to the bearing capacity of the contact patch depends on the backfilling materials on sides, the degree of consolidation as well as the entire covering height (P). The better the consolidation, that much better will be the load transfer. The greater the traffic load, the greater the distribution of load by an appropriately specified construction height.

The following table mentions the load bearing capacity. The entire cover (P) above tunnel shoulder is to be maintained depending on the traffic load, regardless of the type of superstructure and road surface.

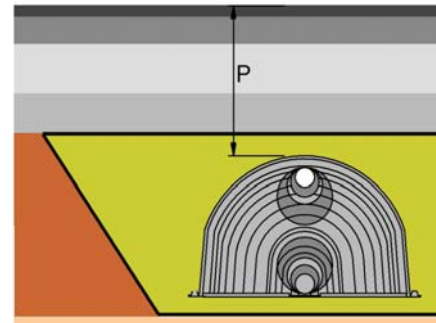

Fig. 16: Total overlying ground P

4.3.1 DRAINMAX Tunnel/60 with DIBt approval

Installation situation / working load	max. axle load	Possible total overlying ground P
Accessible gravel surface	--	0.50 ¹ – 3.00 m
12 t Lorry (alternative surface load = 6.7 kN/m ²), gravel surface	8.0 t	0.50 ^{1,2} – 2.75 m
Heavy goods vehicle HGV 30 (alternative surface load = 16.7 kN/m ²), paved surface	13.0 t	1.00 – 2.00 m
Heavy goods vehicle HGV60 (alternative surface load = 33.4 kN/m ²), paved surface	20.0 t	1.00 – 1.65 m

¹ Valid only if the installation range is reported as frost-proof.

² The formation of lane grooves has to be considered at unhitched areas. The minimum total cover may not be exceeded!

Tab. 6a: Overview of the allowed total overlying ground (Traffic loads according to DIN 1072)

4.3.2 DRAINMAX Tunnel/12

Installation situation / working load	max. axle load	Possible total overlying ground P
Accessible gravel surface	--	0.50 ¹ – 2.25 m
12 t Lorry (alternative surface load = 6.7 kN/m ²), gravel surface	8.0 t	0.80 ^{1,2} – 1.50 m

¹ Valid only if the installation range is reported as frost-proof.

² The formation of lane grooves has to be considered at unhitched areas. The minimum total cover may not be exceeded!

Tab. 6b: Overview of the allowed total overlying ground (Traffic loads according to DIN 1072)

4.3.3 Object-specific calculation for special edge condition

This user guideline describes the relevant standardised installation conditions. The installation and edge conditions different from it are not covered by the existing structural standards.

The INTEWA GmbH will be glad to assist you with the project-related 3D FEM simulation by means of object-specific structural standards.

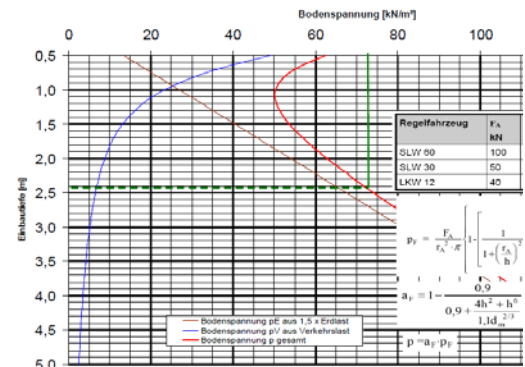

Fig. 17: Determining the installation depth

4.4 Overview of construction with paved traffic areas as per RStO 01¹

The DRAINMAX[®] Tunnel is approved for installation under parking areas including heavy traffic. This corresponds to the classification of construction class BK V according to RStO¹ 01. The traffic surface can be made in asphalt, concrete or plaster. The segmentation in structural level can be determined on the basis of construction class (type of traffic load) depending on the type and thickness. The load bearing capacities of the structural layers are defined by respectively associated deformation E_{v2} .

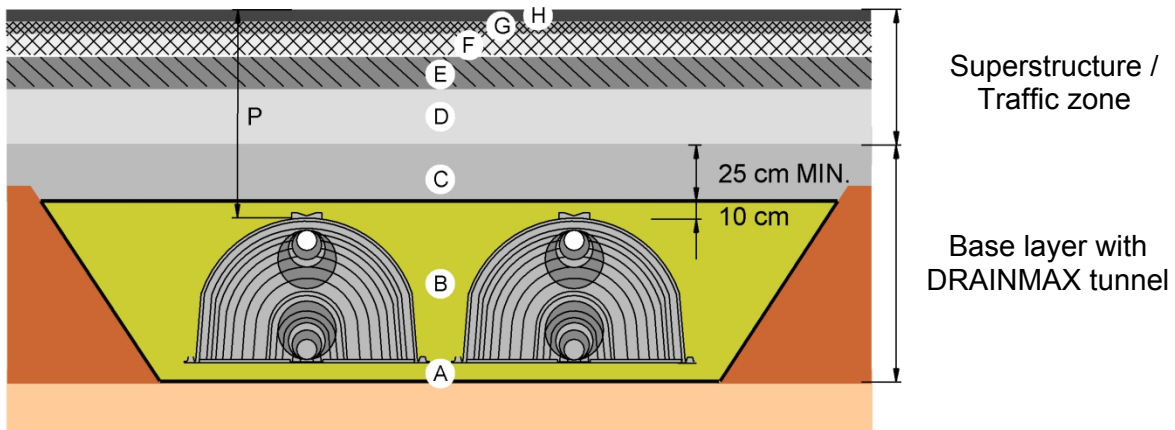





Fig. 18: Example of base layer / superstructure with bituminous cover in accordance with RStO classification V, Line 3.1¹

- A = Sustainable ground layer
- B = Filling, for instance, with gravel 16/32 mm
- C = Tunnel covering (45MN/m²)
- D = Anti-freeze layer (45MN/m²)
- E = Ballast substructure (120MN/m²)
- F = Bituminous base layer (150MN/m²)
- G = Binding layer
- H = Covering layer
- P = Total overlying ground

¹ Official German guidelines for the standardization of traffic surfaces

4.5 Load capacity during installation



The open half-shell structure is structurally loose without side and top backfilling. By the deformations due to high installation loads are avoided this way. Usually, the direct driving of the tunnel elements with construction vehicles or with consolidating devices is not allowed.

Height specification	Consolidating device
0 to 50 cm above ground level	<p>(1)</p> <p>vibrating plates: Operating weight: approx. max. 100 kg Plate width: 380 mm x 500 mm Vibrating force: 12 kN Vibrating frequency: 85Hz</p> 
50 to 120 cm above ground level	<p>(2)</p> <p>Vibrating plates: Operating weight: approx. 255 kg Plate width: 600 mm x 800 mm Specific support pressure: 0.86 since N/cm² Vibrating force: 35 kN Vibrating frequency: 80Hz</p> 
from 40 cm above tunnel shoulder	<p>(3)</p> <p>e.g. Vibrating plates: Operating weight: approx. 400 kg Plate width: 450 mm Vibrating force: 59 kN Vibrating frequency: 65Hz</p> 
from 80 cm onwards above tunnel shoulder	<p>(4)</p> <p>e.g. Vibrating plates: Operating weight: approx. 760 kg Plate width: 700 mm Vibrating force: 100 kN Vibrating frequency: 56Hz</p> 

Tab. 7: Consolidating device for backfilling from sides and top



The compression may only be done with plane vibratory plates. Vibrating tamper and vibratory rollers are not permitted!

Height specifications	Construction vehicle	
<ul style="list-style-type: none"> - starting from 40 cm <u>com- pacted</u> covering on tunnel shoulder 	Crawler excavator <ul style="list-style-type: none"> - Total weight max. 20 t - Spare distributed load < 5 KN/m² 	
<ul style="list-style-type: none"> - starting from 60 cm <u>com- pacted</u> covering on tunnel shoulder 	Wheeled vehicle <ul style="list-style-type: none"> - with max. Wheel load of 4 t, that may not exceed by dumping - Spare distributed load max. 6,7 KN/m² 	
<ul style="list-style-type: none"> - starting from 80 cm <u>com- pacted</u> covering on tunnel shoulder 	Wheeled vehicle <ul style="list-style-type: none"> - with max. Wheel load of 6.5 t, that may not exceed by dumping - Spare distributed load max. 16,7 KN/m² 	

Tab. 8: Permitted load of construction vehicle during tunnel installation

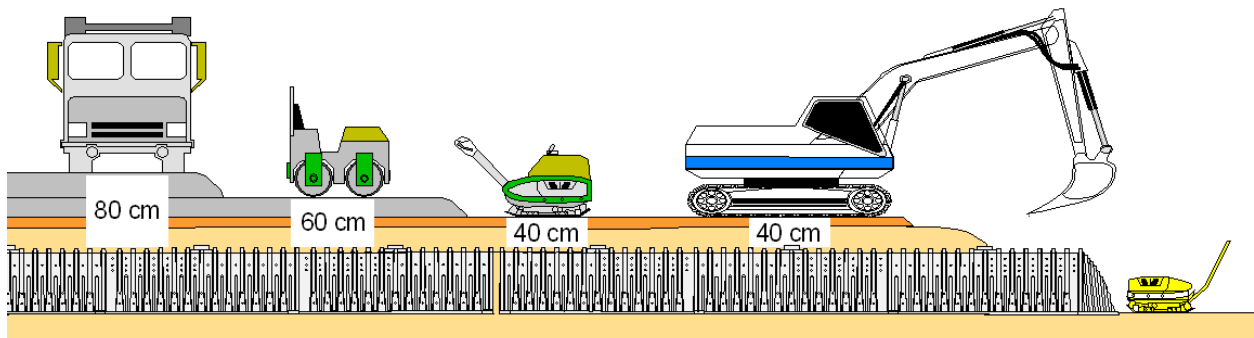

Fig. 19: Overview of construction machines and vehicle

4.6 Woven filter fabric at the base of the tunnel

For applications in which it is possible to clean the base of the tunnel, the INTEWA woven filter fabric GTB 190 is installed in the bottom area of the tunnels.

This later allows efficient cleansing of the sediments settled at the tunnel base. The backfilling of tunnel system is done with fell or gravel from sides as described.

The woven filter fabric is laid in the channel within the flushing tunnel. There must be no overlappings. The compound filter fabric must extend to at least 300 mm on the sides in order to be appropriately clamped in the soil. The adjacent tunnels must maintain an appropriate distance.

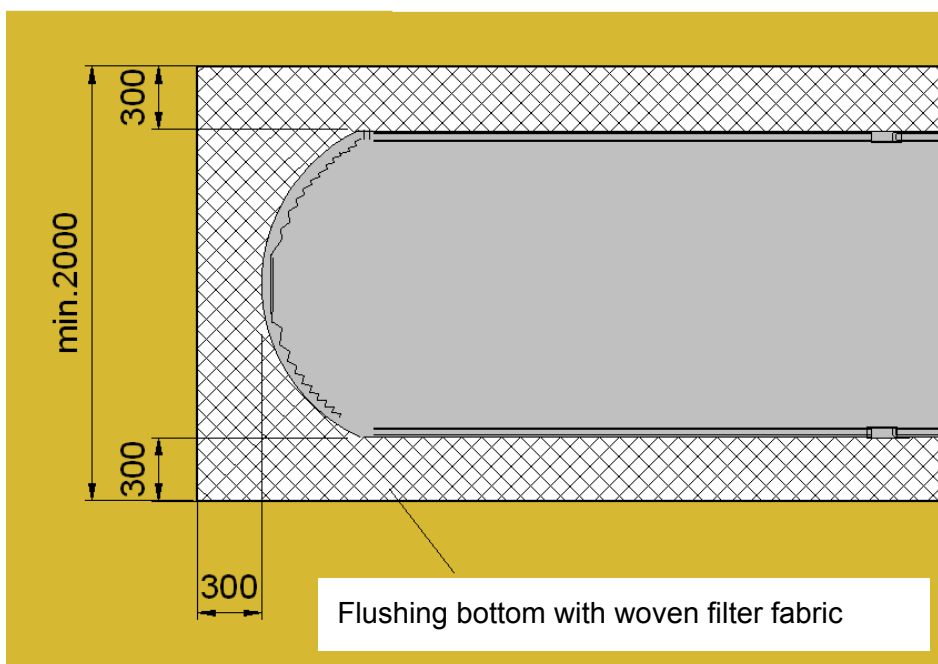

Fig. 21: Compound filter fabric in bottom area of the flushing tunnel

The used woven filter fabric must fulfill following requirements:

Minimum width:	2 m
Stamping push through force:	>3960 N, as per EN ISO 12236
Max. tensile strength longitudinal / diagonal:	40 / 40 kN/m as per EN ISO 10319
Max. tensile strength expansion longitudinal / diagonal:	10 / 8%
Opening width:	0.2 mm
Water permeability $V_{I_{H50}}$:	29 l/sm ²

4.7 Filter fabric cover

The filter fabric is used whenever there is a risk of fells entering into the tunnel.

When backfilling with non-cohesive material, then the tunnels are to be covered with filter fabric. An oversized filter fabric must be placed on the tunnel rows, so that it can follow the serrated structure and could be filled completely with soil in serrated area during backfilling. The overstretching of filter fabric is to be avoided in cavities.

The fabric must have a minimum width of 2.5 m for direct covering of tunnel.

It is not necessary to directly cover the tunnel rows with filter fabric while backfilling it with 16/32 mm gravel. Here, the filter fabric is possibly used only as a separating layer to the final earth covering.

The tunnel bottom is generally covered with filter fabric or geocomposites (flushing tunnel).

If pipes are directed through the filter fabric, then the fabric is to be cut at the appropriate place with undersize, so that the pipe can be tightly routed through the cuts. Overlaps must be directed with at least 50.

The used filter fabric must fulfill following requirements:

Filter fabric sturdiness class:	GRK 5
Minimum width:	2.5 m
Stamping push through force:	3500 N, as per EN ISO 12236
Max. tensile strength longitudinal / diagonal:	24 / 28 kN/m as per EN ISO 10319
Max.expension longitudinal / diagonal:	70 / 80%
Opening width:	0.06 mm
Water permeability VI_{H50} :	36 l/sm ²

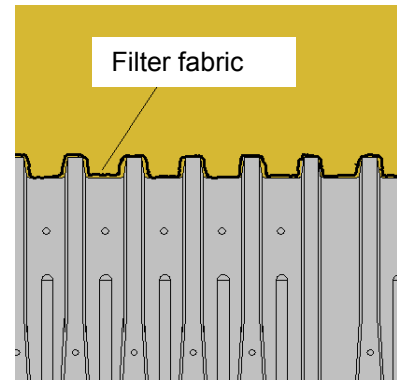

Fig. 20 covering of the Filter fabric on the tunnel rows

5 Overview of installation steps

Construction pit and ground level

The construction pit is to be created as specified in the plan. In doing so, the DIN 18300 ("Groundwork operations"), DIN 4124 ("construction pits and ditches, embankments, pit lining") and if necessary, DIN 4123 ("building security within the scope of excavation") are to be observed.

- Establishing a horizontal, even and stable base layer (for infiltration purposes, the permeability of the compacted subsoil must at least correspond with the permeability mentioned in plan specifications.)
- A separating layer of filter fabric is used installed at ground level and at embankment of construction pit when using 16/32 mm gravel as backfilling material. When the backfilling material is non-cohesive, the tunnel has to be covered all-over with filter fabric.
- The filter fabric is placed under the row of tunnel
- The ground level is to be created with examination of the load bearing capacity as mentioned in the plan specifications.

Laying the tunnel elements and establishing pipe connections

Before the tunnel is laid, the inflow and inspection pits must be installed at the appropriate position and height and the tunnel bottom must be strengthened by filter fabric.

- Place the DRAINMAX[®] elements on the prepared ground in rows with placed filter fabric.
- The first tunnel is laid down starting from the intake pit with start section. The elements are connected with each other by overlapping. The end cap closes the tunnel row. After this, place the next row parallel as per the distance specified in the layout plan.



Image 5: Ditching the pit



Image 6: dyn. Plate load test at ground level



Image 7: Woven filter fabric on bottom area



Image 8: Line to inflow pit



Image 9: Form lock fixing of two tun-

- Cover rows of tunnel with filter fabric and arrange it in such a way that the fabric can adapt to the serrations when covered with soil. Avoid overstretched fabric at cavities. (If using 16/32 gravel, the rows of tunnel are not required to be covered directly.)
- Secure foot embankment with soil in order to fix filter fabric.

Backfilling of tunnel elements from sides

The tunnel element is backfilled from both sides and top with suitable backfilling material in uniform layers of maximum 20 cm

- The uniform compacting of backfilling layers is done with light consolidating device. With increasing altitude heavy consolidating devices may be used (see Chapter 4.4)

Covering the tunnel elements

The load bearing capacity for connected road superstructures is to be taken into account while covering the tunnel elements.

- The backfilling material with mixed grading curve is consolidated in layers above the tunnel shoulder up till the required load bearing capacity is obtained.
- When using 16/32 mm gravel, it is backfilled up to 10 cm above the tunnel shoulder backfilled and is covered flat with a separate layer of filter fabric. The filter fabric is beaten down from all sides (at least 50 cm overlapping). It is further backfilled and compacted in layers with non-binding soil material till the required capacity of 45 kN/m² is attained.

Superstructure for paved road surfaces

Finally, the superstructure is created for the road surfaces as per plan specifications.



Image 10: Covering with filter fabric



Image 11: Backfilling filter fabric for fixing



Image 12: Compacting with a small compacting device between rows of tunnel



Image 13: Covering the tunnel elements

6 Service

6.1 Inspection and Maintenance

The upstreamed rainwater cleaning systems are to be regularly maintained and cleaned. You can obtain details on maintenance of INTEWA sedimentation and filter pits at www.intewa.de.

One advantage of the DRAINMAX® tunnel system is its open hollow structure. You can completely inspect and flush the bottom and wall of the tunnel by suitable connection pipe, which are both critical for long term infiltration performance.

The infiltration capacity can be recorded and examined by measuring the change in water level. If the infiltration capacity deviates more than 25 % of the output, then the cause has to be determined by a camera inspection, for example, the thickness of sedimentation has to be checked.

The area of flushing tunnel can be cleaned and the sediments can also be removed by using the high pressure cleaning procedure consisting of jet nozzle. Local drainage cleaning companies have the necessary equipment for extraction, rinsing and cleaning this. You can find detailed information on the inspection, maintenance and remote monitoring system at www.intewa.de.



Image 14: Image: Drainage cleaning system



Image 15: High pressure cleaning

The throttle system has to be checked for free movement and permeability with attenuation systems. You can find detailed information on INTEWA products at www.intewa.de

6.2 References

The INTEWA DRAINMAX[®] tunnel is extremely popular in the country as well as abroad with more than 25,000 installed m³. You can refer a number of references at www.intewa.de.



Image 16: References

6.3 Warranty and manufacturer's guarantees

This user manual represents the intended use and describes the underground installation of DRAINMAX[®] tunnel. If used other than the intended purpose as well as in conditions other than mounting and basic use (especially different filling material), then they are not covered by this structural analysis.

The general business terms and conditions for the INTEWA manufacturer's guarantee can be found at www.intewa.de.

